

Inductive Proximity Sensor

E2FQ

Sensor Insusceptible to Spatter During Welding

- Housing and mounting nuts are made of Teflon resin resistant to welding spatter and chemicals.
- Watertight housing conforms to IEC IP67.
- Oil-tight cord applied.
- Both two-and three-wire types available for DC switching models.



Ordering Information

■ Teflon Case Models

Size	Shield	Sensing distance	DC 3-wire models			DC 2-wire models		AC 2-wire models	
			PNP (NO)	NPN (NO)	Response frequency	NO	Response frequency	NO	Response frequency
M12	Shielded	2 mm	E2FQ-X2F1	E2FQ-X2E1	1.5 kHz	E2FQ-X2D1	800 Hz	---	---
M18		5 mm	E2FQ-X5F1	E2FQ-X5E1	600 Hz	E2FQ-X5D1	500 Hz	E2FQ-X5Y1	25 Hz
M30		10 mm	E2FQ-X10F1	E2FQ-X10E1	400 Hz	E2FQ-X10D1	300 Hz	E2FQ-X10Y1	

Specifications

■ Ratings/Characteristics

Item	E2FQ-X2E1, E2FQ-X2D1, E2FQ-X2F1	E2FQ-X5E1, E2FQ-X5D1, E2FQ-X5F1, E2FQ-X5Y1	E2FQ-X10E1, E2FQ-X10D1, E2FQ-X10F1, E2FQ-X10Y1
Supply voltage (operating voltage range)	E1 and F1 models: 12 to 24 VDC (10 to 30 VDC), ripple (p-p): 10% max. D1 models: 12 to 24 VDC (10 to 36 VDC), ripple (p-p): 20% max. Y1 models: 24 to 240 VAC (20 to 264 VAC), 50/60 Hz		
Current consumption	E1 and F1 models: 17 mA max.		
Leakage current	D1 models: 0.8 mA max. Y1 models: 1.7 mA max. at 200 VAC		
Sensing object	Ferrous metal (refer to <i>Engineering Data</i> for non-ferrous metal)		
Sensing distance	2 mm ±10%	5 mm ±10%	10 mm ±10%
Sensing distance (standard object)	0 to 1.6 mm (iron, 12 x 12 x 1 t)	0 to 4 mm (iron, 18 x 18 x 1 t)	0 to 8 mm (iron, 30 x 30 x 1 t)
Differential travel	E1, F1 and Y1 models: 10% max. of sensing distance D1 models: 20% max. of sensing distance		
Response frequency (see note 1)	E1 and F1 models: 1.5 kHz, D1 models: 800 Hz	E1 and F1 models: 600 Hz, D1 models: 500 Hz	E1 and F1 models: 400 Hz, D1 models: 300 Hz
	---	Y1 models: 25 Hz	
Operating status (with sensing object approaching)	E1 and F1 models: L output signal with load ON D1 models: Load ON Y1 models: Load ON		
Control output (switching capacity)	E1 and F1 models: 200 mA max. D1 models: 5 to 100 mA DC Y1 models: 5 to 300 mA		
Circuit protection	E1 and F1 models: Reverse connection protection, load short-circuiting protection, and surge absorber D1 and Y1 models: Surge absorber		
Ambient temperature	Operating: -25°C to 70°C (with no icing)		
Ambient humidity	Operating: 35% to 95%		
Temperature influence	±10% max. of sensing distance at 23°C in the temperature range of -25°C to 70°C		
Voltage influence	E1 and F1 models: ±2.5% max. of sensing distance within a range of ±15% of the rated power supply voltage D1 models: ±2.5% max. of sensing distance within a range of ±20% of the rated power supply voltage Y1 models: ±1% max. of sensing distance within a range of ±10% of the rated power supply voltage		
Residual voltage	E1 and F1 models: 2.0 V max. under a load current of 200 mA and a cord length of 2 m D1 models: 4.0 V max. under a load current of 100 mA and a cord length of 2 m Y1 models: Refer to <i>Residual Load Voltage (Typical)</i> on page 3.		
Insulation resistance	50 MΩ min. (at 500 VDC) between current carry parts and case		
Dielectric strength	E1, F1 and D1 models: 1,000 VAC, 50/60 Hz for 1 min between current carry parts and case Y1 models: 4,000 VAC, 50/60 Hz for 1 min between current carry parts and case		
Vibration resistance	Destruction: 10 to 55 Hz, 1.5-mm double amplitude for 2 hours each in X, Y, and Z directions		
Shock resistance	Destruction: 500 m/s ² (approx. 50G) 10 times each in X, Y, and Z directions		Destruction: 1,000 m/s ² (approx. 100G) 10 times each in X, Y, and Z directions
Degree of protection	IEC60529 IP67		
Weight	Approx. 70 g	Approx. 130 g	Approx. 170 g
Material	Case	Teflon (see note 2)	
	Sensing surface	Teflon (see note 2)	

- Note:**
- The response frequencies of the DC switching components are average values obtained by measuring in sequence a line-up standard sensing objects. The space between any adjacent sensing objects was twice the width of a single sensing object and the setting distance was half the maximum sensing distance.
 - Teflon is a registered trademark of the Dupont Company and the Mitsui Dupont Chemical Company for their fluoride resin.

Engineering Data

Operating Range (Typical)

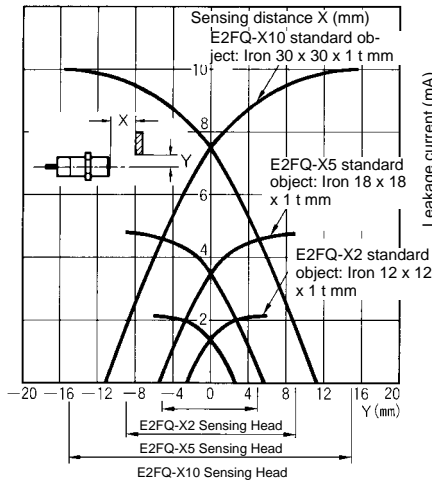

Leakage Current (Typical)

E2FQ-X2D1, E2FQ-X5D1, E2FQ-X10D1

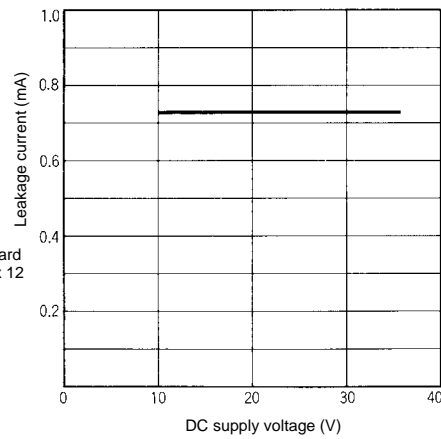

E2FQ-X5Y1, E2FQ-X10Y1

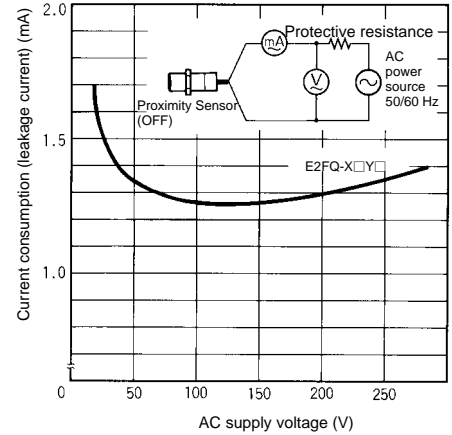

Residual Load Voltage (Typical)

E2EQ-X5Y1, E2FQ-X10Y1
 (at constant 24 VAC)

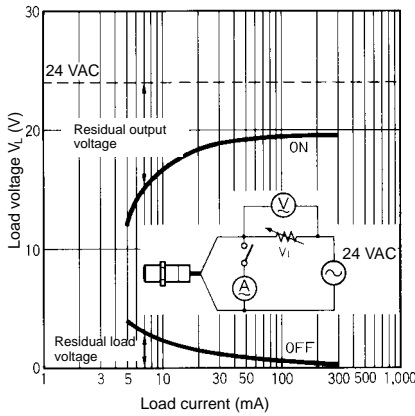

(at constant 100 VAC)

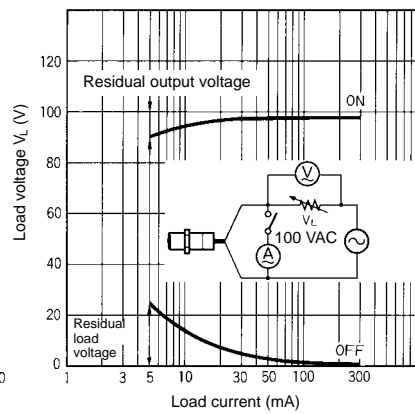

(at constant 200 VAC)

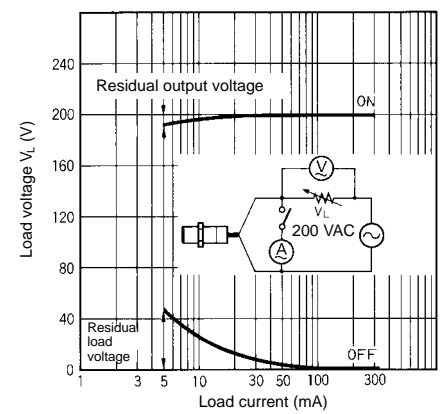

Sensing Object Size and Material vs. Sensing Distance (Typical)

E2FQ-X2

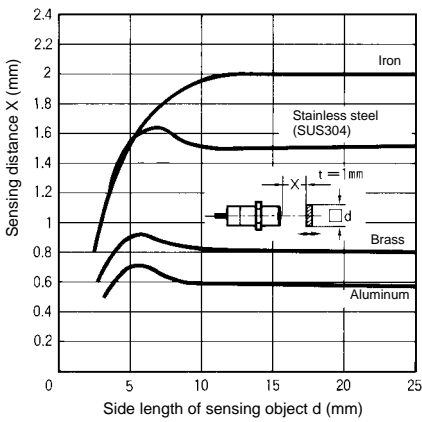

E2FQ-X5

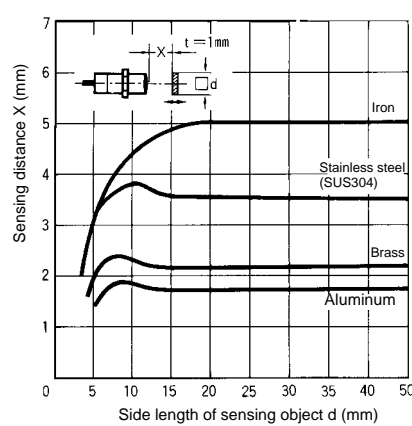

E2FQ-X10

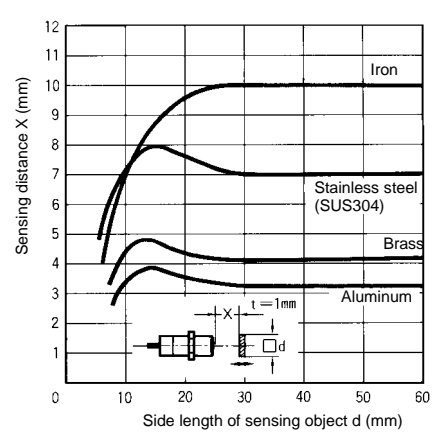

Operation

Output Circuits

E1 Models

NPN (DC 3-wire)

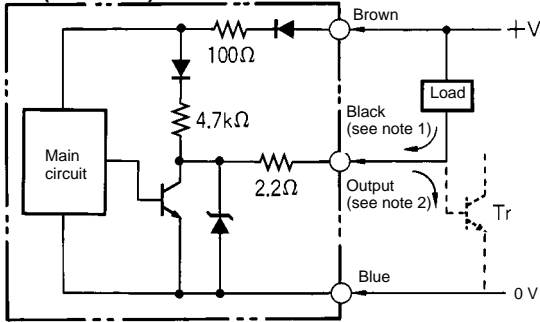

- Note:** 1. 200 mA max. (load current)
2. When a transistor is connected

D1 Models

(DC 2-wire)

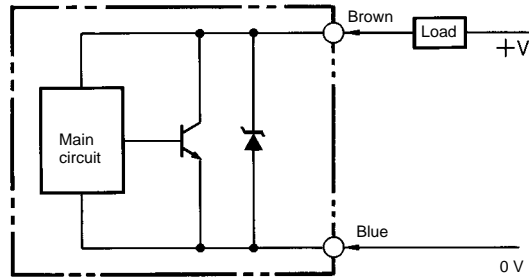

F1 Models

PNP (DC 3-wire)

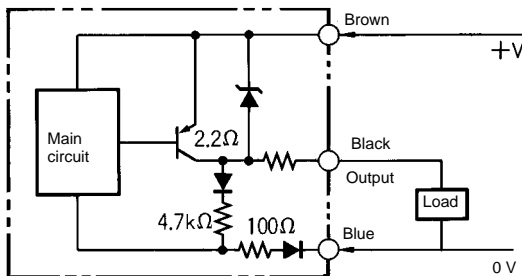

Y1 Models

(AC 2-wire)

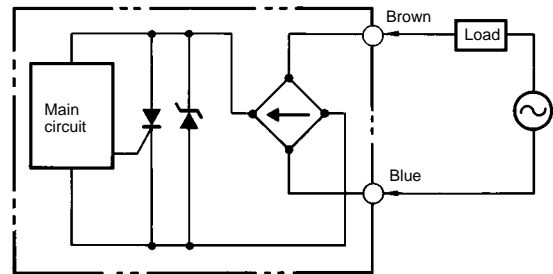

Timing Charts

E1 Models

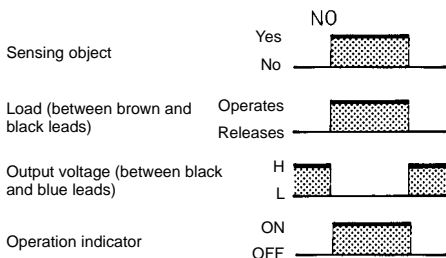

F1 Models

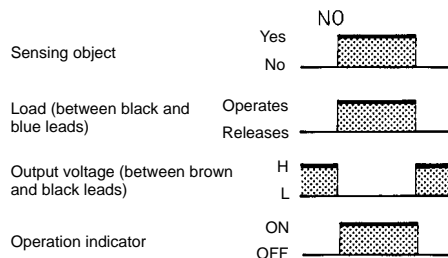

D1 Models

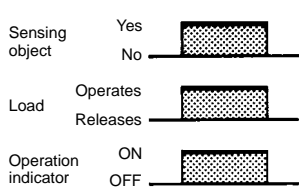

Y1 Models

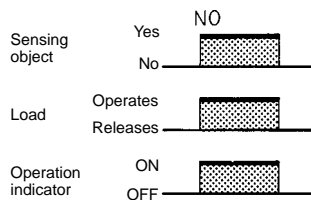

Note: Like the E2EQ, the load can be connected in two ways.

Dimensions

Note: All units are in millimeters unless otherwise indicated.

E2FQ-X2E1, E2FQ-X2F1

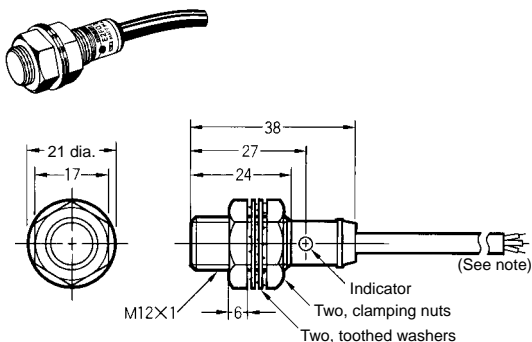

Note: Oil-resistant, vibration-resistant, and fire-retardant vinyl-insulated round cord, 6 dia., 0.5 dia. x 3 cores, standard length: 2 m
The cord can be extended in an independent conduit for 200 m maximum.

E2FQ-X2D1

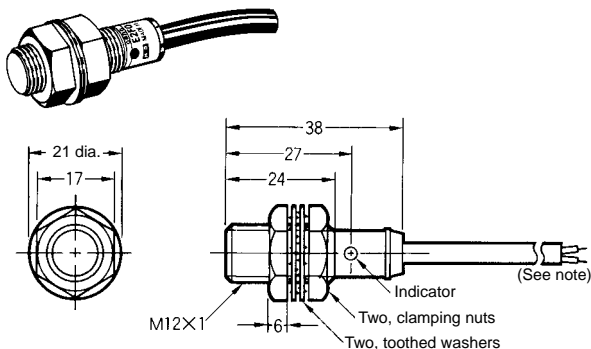

Note: Oil-resistant, vibration-resistant, and fire-retardant vinyl-insulated round cord, 6 dia., 0.5 dia. x 2 cores, standard length: 2 m
The cord can be extended in an independent conduit for 200 m maximum.

E2FQ-X5E1, E2FQ-X5F1

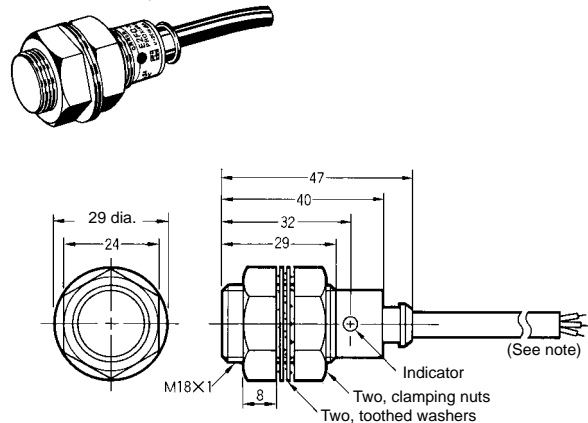

Note: Oil-resistant, vibration-resistant, and fire-retardant vinyl-insulated round cord, 6 dia., 0.5 dia. x 3 cores, standard length: 2 m
The cord can be extended in an independent conduit for 200 m maximum.

E2FQ-X5D1, E2FQ-X5Y1

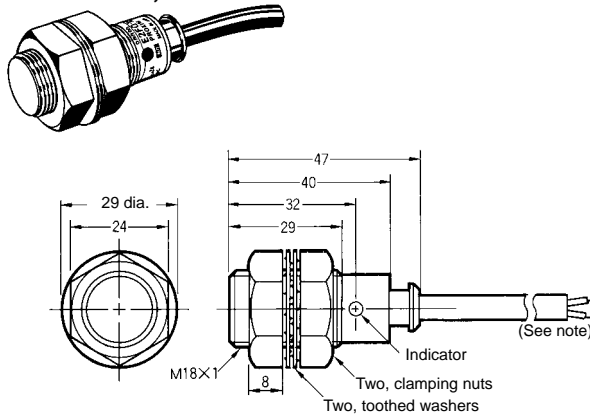

Note: Oil-resistant, vibration-resistant, and fire-retardant vinyl-insulated round cord, 6 dia., 0.5 dia. x 2 cores, standard length: 2 m
The cord can be extended in an independent conduit for 200 m maximum.

E2FQ-X10E1, E2FQ-X10F1

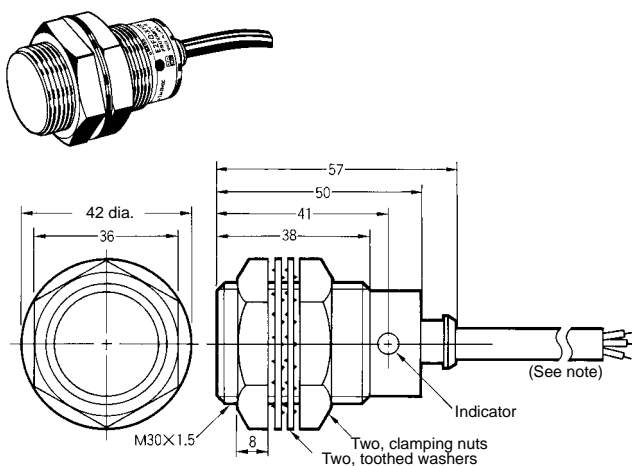

Note: Oil-resistant, vibration-resistant, and fire-retardant vinyl-insulated round cord, 6 dia., 0.5 dia. x 3 cores, standard length: 2 m
The cord can be extended in an independent conduit for 200 m maximum.

E2FQ-X10D1, E2FQ-X10Y1

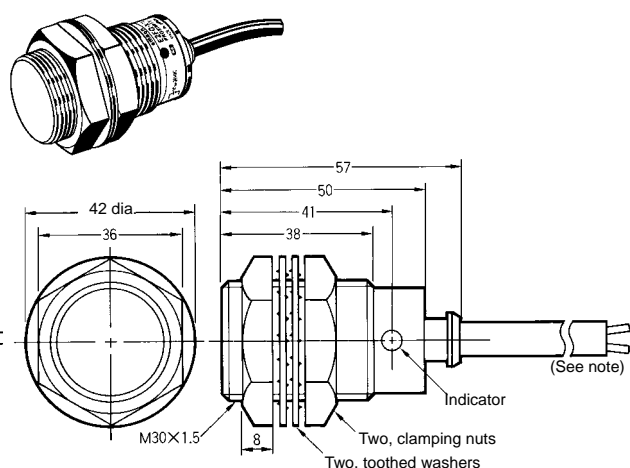

Note: Oil-resistant, vibration-resistant, and fire-retardant vinyl-insulated round cord, 6 dia., 0.5 dia. x 2 cores, standard length: 2 m
The cord can be extended in an independent conduit for 200 m maximum.

Mounting Holes

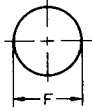

Model	F (mm)
E2FQ-X2	12.5 ^{+0.5} / ₀ dia.
E2FQ-X5	18.5 ^{+0.5} / ₀ dia.
E2FQ-X10	30.5 ^{+0.5} / ₀ dia.

Precautions

Mounting

Do not tighten the clamping nuts with excessive force.

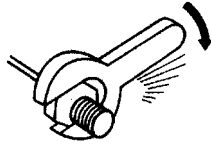

The tightening torques listed in the table below apply when the two toothed washers are used, and are also applicable to the AC switching model.

Model	Torque
E2FQ-X2	0.98 N • m (10 kgf • cm)
E2FQ-X5	2.0 N • m (20 kgf • cm)
E2FQ-X10	2.0 N • m (20 kgf • cm)

Effects of Surrounding Metals

When mounting a Proximity Sensor flush with a metallic panel, be sure to provide a minimum distance as shown for each model in the table below, to prevent the Sensor from being affected by metallic objects other than the sensing object.

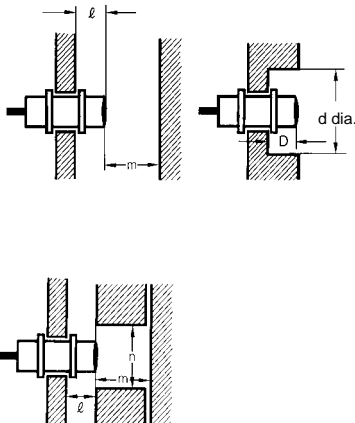

(Unit: mm)

Distance	Model		
	E2FQ-X2	E2FQ-X5	E2FQ-X10
ℓ	0	0	0
d	12	18	30
D	0	0	0
m	8	20	40
n	18	27	45

Mutual Interference

When two or more Proximity Sensors are installed face-to-face or side-by-side, provide a space between the two Sensors as shown in the table below.

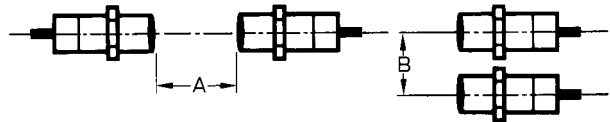

(Unit: mm)

Distance	Model		
	E2FQ-X2	E2FQ-X5	E2FQ-X10
A	30	50	100
B	20	35	70

Connection to Power Source for AC Type

Be sure to connect the Proximity Sensor to a power source through a load. Direct connection may damage the Sensor.

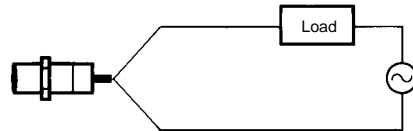

ALL DIMENSIONS SHOWN ARE IN MILLIMETERS.

To convert millimeters into inches, multiply by 0.03937. To convert grams into ounces, multiply by 0.03527.

Cat. No. D029-E1-3A **In the interest of product improvement, specifications are subject to change without notice.**

OMRON Corporation

Industrial Sensors Division
Sensing Devices and Components Division H.Q.
28th Fl., Crystal Tower Bldg.
1-2-27, Shiromi, Chuo-ku,
Osaka 540-6028 Japan
Phone: (81)6-949-6012 Fax: (81)6-949-6021

Printed in Japan
0898-2M (0888) Ⓐ