

**G3ZA**

# **Multi-channel Power Controller**

# **USER'S MANUAL**

**OMRON**

# **G3ZA**

## **Multi-channel Power Controller**

### **User's Manual**

*Produced April 2004*



## ***Preface***

OMRON products are manufactured for use according to proper procedures by a qualified operator and only for the purposes described in this manual.

This manual describes the functions, performance, and application methods needed for optimum use of the G3ZA.

Please observe the following items when using the G3ZA.

- This product is designed for use by qualified personnel with a knowledge of electrical systems.
- Read this manual carefully and make sure you understand it well to ensure that you are using the G3ZA correctly.
- Keep this manual in a safe location so that it is available for reference when required.

© **OMRON, 2004**

All rights reserved. No part of this publication may be reproduced, stored in a retrieval system, or transmitted, in any form, or by any means, mechanical, electronic, photocopying, recording, or otherwise, without the prior written permission of OMRON.

No patent liability is assumed with respect to the use of the information contained herein. Moreover, because OMRON is constantly striving to improve its high-quality products, the information contained in this manual is subject to change without notice. Every precaution has been taken in the preparation of this manual. Nevertheless, OMRON assumes no responsibility for errors or omissions. Neither is any liability assumed for damages resulting from the use of the information contained in this publication.

## Read and Understand this Manual

Please read and understand this manual before using the product. Please consult your OMRON representative if you have any questions or comments.

## Warranty and Limitations of Liability

### WARRANTY

OMRON's exclusive warranty is that the products are free from defects in materials and workmanship for a period of one year (or other period if specified) from date of sale by OMRON. OMRON MAKES NO WARRANTY OR REPRESENTATION, EXPRESS OR IMPLIED, REGARDING NON-INFRINGEMENT, MERCHANTABILITY, OR FITNESS FOR PARTICULAR PURPOSE OF THE PRODUCTS. ANY BUYER OR USER ACKNOWLEDGES THAT THE BUYER OR USER ALONE HAS DETERMINED THAT THE PRODUCTS WILL SUITABLY MEET THE REQUIREMENTS OF THEIR INTENDED USE. OMRON DISCLAIMS ALL OTHER WARRANTIES, EXPRESS OR IMPLIED.

### LIMITATIONS OF LIABILITY

OMRON SHALL NOT BE RESPONSIBLE FOR SPECIAL, INDIRECT, OR CONSEQUENTIAL DAMAGES, LOSS OF PROFITS OR COMMERCIAL LOSS IN ANY WAY CONNECTED WITH THE PRODUCTS, WHETHER SUCH CLAIM IS BASED ON CONTRACT, WARRANTY, NEGLIGENCE, OR STRICT LIABILITY.

In no event shall the responsibility of OMRON for any act exceed the individual price of the product on which liability is asserted.

IN NO EVENT SHALL OMRON BE RESPONSIBLE FOR WARRANTY, REPAIR, OR OTHER CLAIMS REGARDING THE PRODUCTS UNLESS OMRON'S ANALYSIS CONFIRMS THAT THE PRODUCTS WERE PROPERLY HANDLED, STORED, INSTALLED, AND MAINTAINED AND NOT SUBJECT TO CONTAMINATION, ABUSE, MISUSE, OR INAPPROPRIATE MODIFICATION OR REPAIR.

## Application Considerations

### SUITABILITY FOR USE

OMRON shall not be responsible for conformity with any standards, codes, or regulations that apply to the combination of products in the customer's application or use of the products.

At the customer's request, OMRON will provide applicable third party certification documents identifying ratings and limitations of use that apply to the products. This information by itself is not sufficient for a complete determination of the suitability of the products in combination with the end product, machine, system, or other application or use.

The following are some examples of applications for which particular attention must be given. This is not intended to be an exhaustive list of all possible uses of the products, nor is it intended to imply that the uses listed may be suitable for the products.

- Outdoor use, uses involving potential chemical contamination or electrical interference, or conditions or uses not described in this manual.
- Nuclear energy control systems, combustion systems, railroad systems, aviation systems, medical equipment, amusement machines, vehicles, safety equipment, and installations subject to separate industry or government regulations.
- Systems, machines, and equipment that could present a risk to life or property.

Please know and observe all prohibitions of use applicable to the products.

NEVER USE THE PRODUCTS FOR AN APPLICATION INVOLVING SERIOUS RISK TO LIFE OR PROPERTY WITHOUT ENSURING THAT THE SYSTEM AS A WHOLE HAS BEEN DESIGNED TO ADDRESS THE RISKS, AND THAT THE OMRON PRODUCTS ARE PROPERLY RATED AND INSTALLED FOR THE INTENDED USE WITHIN THE OVERALL EQUIPMENT OR SYSTEM.

### PROGRAMMABLE PRODUCTS

OMRON shall not be responsible for the user's programming of a programmable product, or any consequence thereof.

## Disclaimers

### **CHANGE IN SPECIFICATIONS**

Product specifications and accessories may be changed at any time based on improvements and other reasons.

It is our practice to change model numbers when published ratings or features are changed, or when significant construction changes are made. However, some specifications of the products may be changed without any notice. When in doubt, special model numbers may be assigned to fix or establish key specifications for your application on your request. Please consult with your OMRON representative at any time to confirm actual specifications of purchased products.

### **DIMENSIONS AND WEIGHTS**

Dimensions and weights are nominal and are not to be used for manufacturing purposes, even when tolerances are shown.

### **PERFORMANCE DATA**

Performance data given in this manual is provided as a guide for the user in determining suitability and does not constitute a warranty. It may represent the result of OMRON's test conditions, and the users must correlate it to actual application requirements. Actual performance is subject to the OMRON Warranty and Limitations of Liability.

### **ERRORS AND OMISSIONS**

The information in this document has been carefully checked and is believed to be accurate; however, no responsibility is assumed for clerical, typographical, or proofreading errors, or omissions.

# Safety Precautions

## ■ Definition of Precautionary Information

The following notation is used in this manual to provide precautions required to ensure safe usage of the product.





The safety precautions that are provided are extremely important to safety. Always read and heed the information provided in all safety precautions.

The following notation is used.





 <b>WARNING</b>	<p>Indicates a potentially hazardous situation which, if not avoided, will result in minor or moderate injury, or may result in serious injury or death. Additionally there may be significant property damage.</p>
--	---

 <b>CAUTION</b>	<p>Indicates a potentially hazardous situation which, if not avoided, may result in minor or moderate injury or in property damage.</p>
--	---

## ■ Symbols

<b>Symbol</b>		<b>Meaning</b>
Caution		<p><b>General Caution</b> Indicates non-specific general cautions, warnings, and dangers.</p>
		<p><b>Electrical Shock Caution</b> Indicates possibility of electric shock under specific conditions.</p>
Prohibition		<p><b>General Prohibition</b> Indicates non-specific general prohibitions.</p>
Mandatory Caution		<p><b>General Caution</b> Indicates non-specific general cautions, warnings, and dangers.</p>

## ■ Precautions

 <b>WARNING</b>	
Do not touch the terminals and the wires while power is being supplied. Doing so may possibly result in electric shock. Make sure that the terminal cover is installed before using the product.	
 <b>CAUTION</b>	
Do not allow pieces of metal, wire clippings, or fine metallic chips or filings from installation to enter the product. Doing so may occasionally result in electric shock, fire, or malfunction.	
Do not use the product in locations of flammable or explosive gases. Doing so may occasionally result in minor or moderate explosion, causing minor or moderate injury, or property damage.	
Do not attempt to disassemble, repair, or modify the product. Doing so may occasionally result in minor or moderate injury due to electric shock.	
Perform correct setting of the product according to the application. Failure to do so may occasionally cause unexpected operation, resulting in minor or moderate injury, or damage to the equipment.	
Ensure safety in the event of product failure by taking safety measures, such as installing a separate monitoring system to provide alarms for preventing excessive temperature rise. Product failure may occasionally prevent control operation, resulting in damage to the connected facilities and equipment.	
Tighten the terminal screws securely using a tightening torque within the following ranges. Loose screws may occasionally cause fire, resulting in minor or moderate injury, or damage to the equipment. Terminal screws: 0.40 to 0.56 N·m	

## Precautions for Safe Use

- (1) Do not use the product in the following locations.
  - Locations subject to direct radiant heat from heating equipment
  - Locations where the product may come into contact with water or oil
  - Locations subject to direct sunlight
  - Locations where dust or corrosive gases (in particular, sulfuric or ammonia gas) are present
  - Locations subject to extreme temperature changes
  - Locations where icing or condensation may occur
  - Locations subject to excessive shocks or vibration
- (2) Use this product within the rated load and power supply.
- (3) Ensure that the rated voltage is achieved no longer than 2 s after turning the power ON.
- (4) Use/store within the rated temperature and humidity ranges. Provide forced-cooling if required.
- (5) Minimum mounting distance of G3ZA is 10 mm.  
When mounting the G3ZA near the SSRs, mount the G3ZA so as to not interfere with the heat dissipation of the SSR.
- (6) Use the specified size of insulated type crimp terminals (M3, width: 5.8 mm max.) for wiring and attach insulative sleeves. To connect bare wires, use AWG22 (cross section: 0.326 mm<sup>2</sup>) to AWG14 (cross section: 2.081 mm<sup>2</sup>) to wire the power supply terminals and AWG22 (cross section: 0.326 mm<sup>2</sup>) to AWG16 (cross section: 1.039 mm<sup>2</sup>) for other terminals.
- (7) Be sure to confirm the correct terminal and polarity when wiring the terminal block and connectors.
- (8) Do not connect any conductors to unused terminals.
- (9) In order to prevent inductive noise, wire the lines connected to the product separately from power lines carrying high voltages or currents. Do not wire in parallel with or in the same cable as power lines. Other measures for reducing noise include running lines along separate ducts and using shield lines.
- (10) Attach a surge suppressor or noise filter to peripheral devices that generate noise (in particular, motors, transformers, solenoids, magnetic coils or other equipment that have an inductance component).  
Do not install the product near devices generating strong high-frequency fields or surges. When using a noise filter, check the voltage and current and install it as close to the product as possible.
- (11) For a safety disconnection of the power-line in the application the equipment shall be provided with disconnecting devices suitable for isolation.  
(e.g. circuit breakers IEC60947-2, power switches IEC60947-3, power plugs etc.)
- (12) The G3ZA is for single-phase loads only. Connect only single-phase zero-cross SSRs.  
Do not connect three-phase SSRs, magnetic relays, or SSRs that do not have zero-cross function.

# TABLE OF CONTENTS

## SECTION 1

<b>Overview</b> .....	<b>1</b>
1-1 Features .....	2

## SECTION 2

<b>Preparations</b> .....	<b>5</b>
2-1 Installation .....	6
2-2 How To Use the Terminals .....	9

## SECTION 3

<b>Using the G3ZA</b> .....	<b>13</b>
3-1 Communications Settings .....	14
3-2 CompoWay/F Frame Structure .....	15
3-3 FINS-mini Text .....	17
3-4 Variable Area Write .....	17
3-5 Variable Area Read .....	18
3-6 Operation Command .....	19
3-7 Controller Attribute Read .....	20
3-8 Controller Status Read .....	21
3-9 Echo-back Test .....	22

## SECTION 4

<b>Functions</b> .....	<b>23</b>
4-1 Changing the Manipulated Variable .....	24
4-2 Offsetting Control Output ON Timing .....	25
4-3 Turning OFF the Control Output .....	25
4-4 Detecting Heater Burnout (4-channel Models Only) .....	26
4-5 Detecting Heater Overcurrent (4-channel Models Only) .....	28
4-6 Detecting SSR Short Circuits (4-channel Models Only) .....	28
4-7 Setting Operation for Errors .....	30
4-8 Detecting Communications Timeouts .....	30

## SECTION 5

<b>Troubleshooting</b> .....	<b>31</b>
5-1 Errors .....	32
5-2 Handling Problems .....	33

<b>Appendix</b> .....	<b>35</b>
-----------------------	-----------

<b>Index</b> .....	<b>43</b>
--------------------	-----------

<b>Revision History</b> .....	<b>45</b>
-------------------------------	-----------



## ***About this Manual:***

This manual describes the installation and operation of the G3ZA Multi-channel Power Controller and includes the sections described below.

Please read this manual carefully and be sure you understand the information provided before attempting to install or operate the G3ZA. Be sure to read the precautions provided at the beginning of this manual.

The **Preface** provides precautions for using the G3ZA and information on using this manual.

**Section 1** introduces the G3ZA and its features.

**Section 2** describes preparations for using the G3ZA, including installation and wiring.

**Section 3** describes application information, including settings, communications, and controlling operation.

**Section 4** describes the functions of the G3ZA so that these functions can be used effectively according to the application.

**Section 5** provides information on problems that may occur during operation and corrective measures.

The **Appendix** provides G3ZA specifications, tables of settings, and other information.

 **WARNING** Failure to read and understand the information provided in this manual may result in personal injury or death, damage to the product, or product failure. Please read each section in its entirety and be sure you understand the information provided in the section and related sections before attempting any of the procedures or operations given.



# SECTION 1 Overview

This section introduces the G3ZA and its features.

1-1	Features .....	2
-----	----------------	---

# 1-1 Features

The G3ZA is a Multi-channel Power Controller with externally connected SSRs. It can receive manipulated variables from a PLC or other host via RS-485 communications and control heater power with high precision via the SSRs.

## Overview

### Optimum Cycle Control

- Optimum cycle control is performed by driving SSRs according to load power detection and trigger signals. (Zero-cross SSRs are used.)
- Noise is suppressed while ensure high-speed response by turning outputs ON and OFF each half cycle to achieve high-precision temperature control.

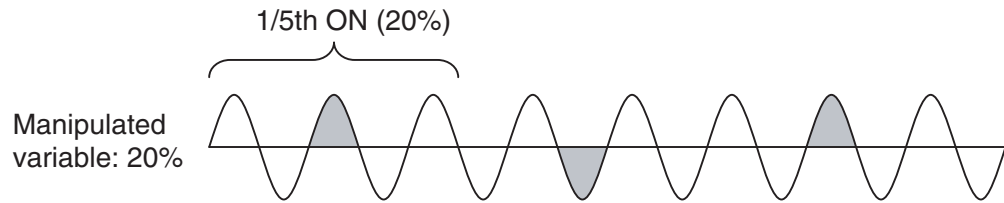

### Offset Control

- The timing of turning ON the control outputs for G3ZA channels can be offset.

### Manipulated Value Calculations

- The manipulated variable can be calculated for one channel and the calculated value can be output for another channel.

### Error Detection (4-channel Controllers Only)

- The current flowing through the heater can be monitored to detect heater burnouts, heater overcurrents, and SSR short circuits.

### Number of Outputs Connected

- Between one and four outputs can be connected to 4-channel Controllers and between one and eight outputs can be connected to 8-channel Controllers.

### Alarm Output

- An open-collector output terminal can be used to inform the host of errors without using communications.

### Installation

- RS-485 communications can be used to set and operate the G3ZA, reducing the amount of wiring required between the G3ZA and host.
- Up to 31 Controllers can be connected to one communications line. With 4-channel Controllers, up to 124 channels can be controlled, and with 8-channel Controllers, up to 248 channels can be controlled.

The following four models are available.

No. of channels	Error detection	Load power supply
4 channels	Supported	100 to 240 V
		400 to 480 V
8 channels	Not supported	100 to 240 V
		400 to 480 V

**Connections**

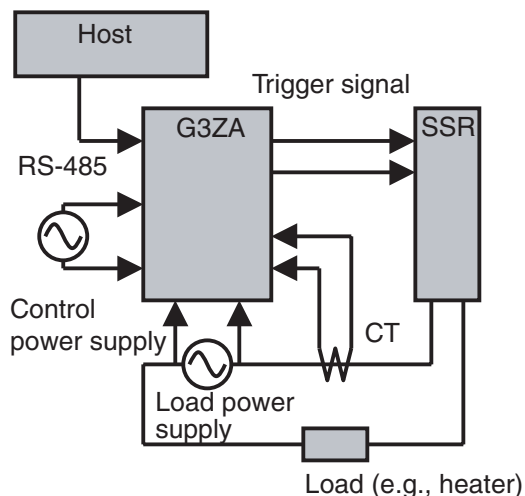

**Note** Connect a power supply with the same phase as the SSRs to the load power supply input terminals on the G3ZA.

**Component Names and Functions**

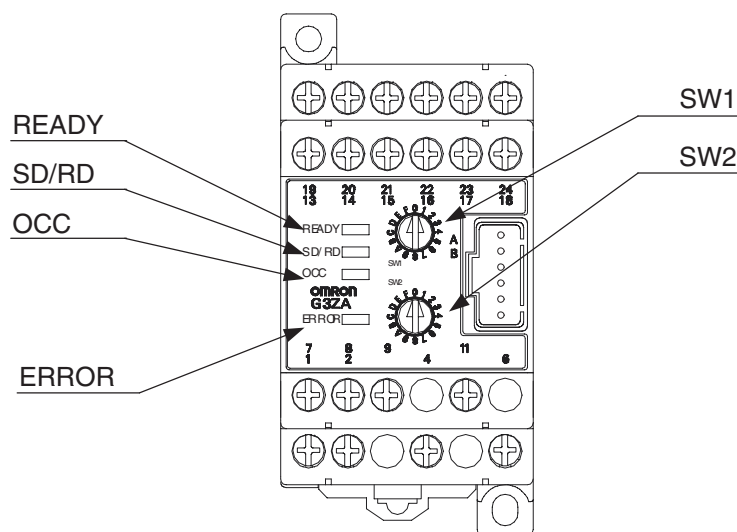

**Operation Indicators**

Operation indicator	Meaning
READY	Lit while power is being supplied.
SD/RD	Lit while communicating with the host.
OCC	Lit while a control output is ON.
ERROR	Lights or flashes when an error is detected.

**Switches SW1 and SW2**

SW1 and SW2 are used to set the communications unit number and baud rate. Refer to 3-1 Communications Settings on page 14 for details.



# SECTION 2 Preparations

This section describes preparations for using the G3ZA, including installation and wiring.

2-1	Installation . . . . .	6
2-2	How To Use the Terminals . . . . .	9

## 2-1 Installation

### Dimensions (Unit: mm)

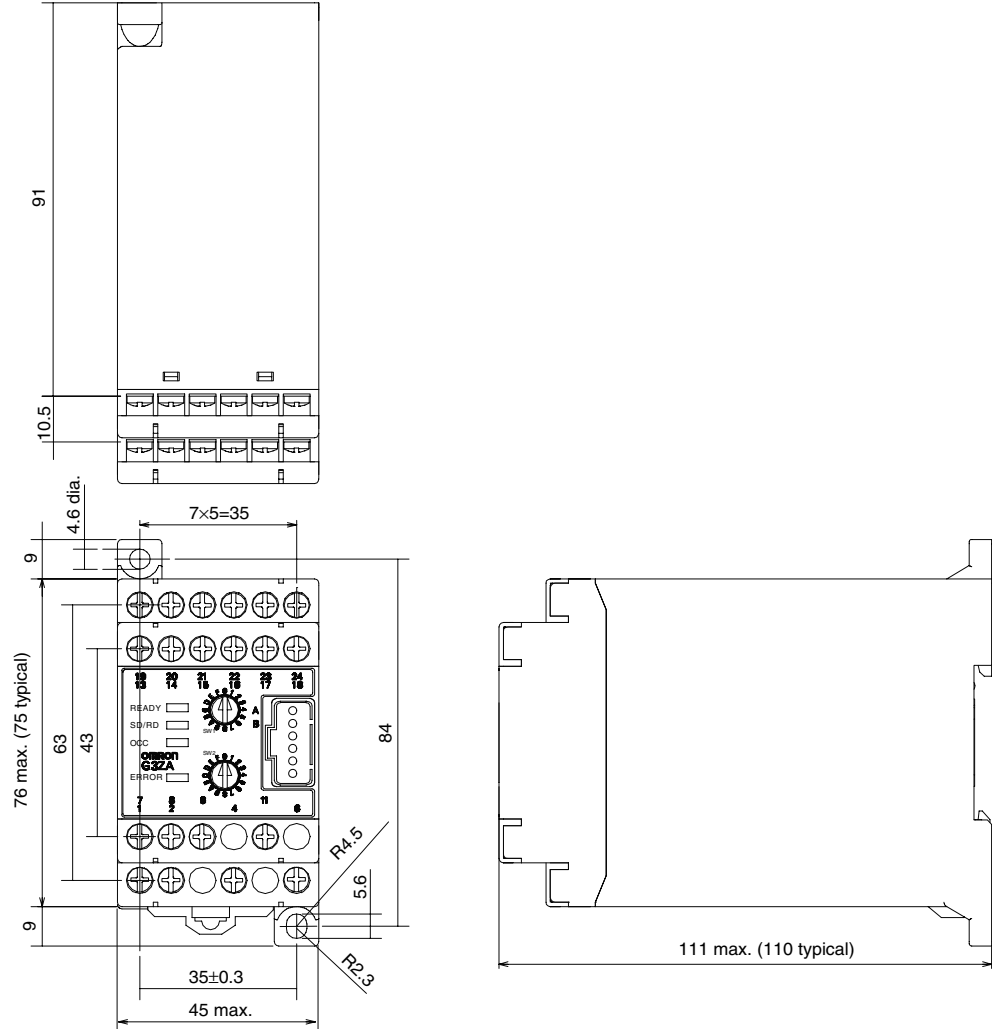

### Mounting to DIN Track

#### DIN Track Products

When installing a DIN Track inside a control panel, secure the DIN Track with screws in at least three locations.

- DIN Track: PFP-50N (50 cm) or PFP-100N (100 cm)

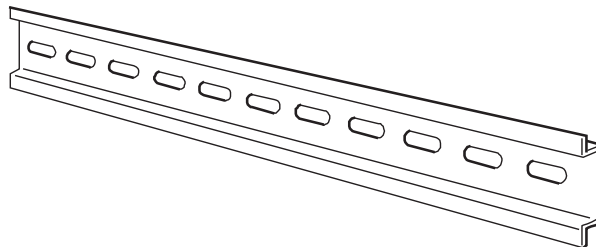

- End Plates: PFP-M

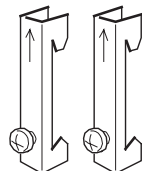

**Mounting the G3ZA**

Mount the G3ZA as shown in the diagram. First, pull down the DIN Track mounting hook (1) and hook the top of the G3ZA on the DIN Track (2). Then press the G3ZA onto the DIN Track far enough so that it can be locked in place (3) and push the DIN Track mounting hook up to lock the G3ZA in place (4).

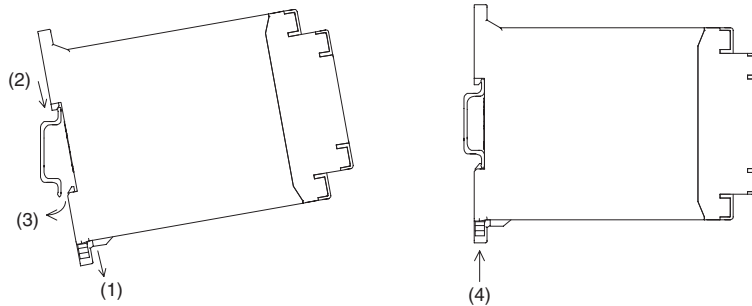

**Removing the G3ZA**

Use a flat-blade screwdriver to pull down the DIN Track mounting hook (1) and then pull out on the bottom of the G3ZA (2).

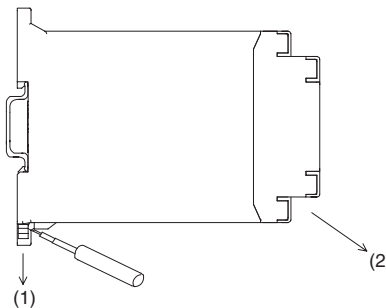

**Mounting End Plates**

Be sure to mount an End Plate on each side of the G3ZA so that it does not slide on the DIN Track.

To mount an End Plate, hook the bottom of the End Plate on the bottom of the DIN Track (1), place the top of the End Plate on the DIN Track (2), and then pull down on the End Plate. Tighten the screw on the End Plate to secure it.

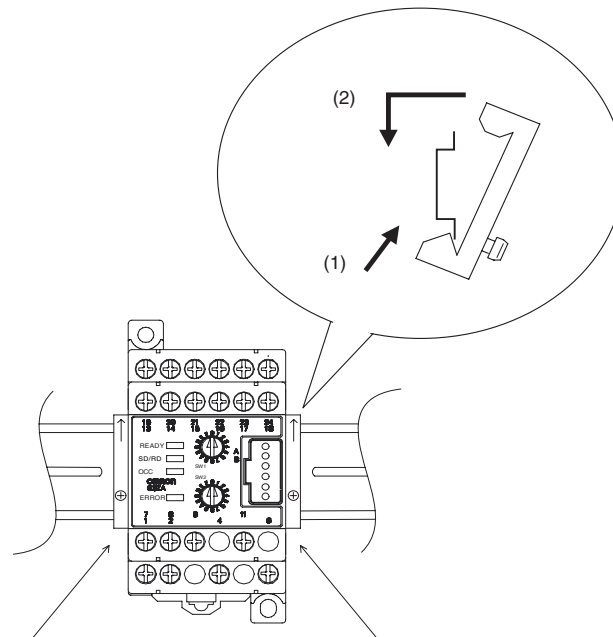

**Note** Always mount one End Plate on each side of the G3ZA.

**Mounting the G3ZA with Screws**

**Mounting Hole  
Dimensions (Unit: mm)**

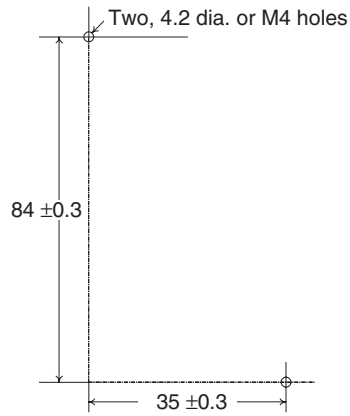

## 2-2 How To Use the Terminals

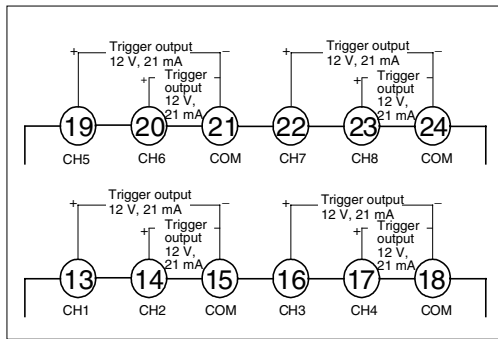

G3ZA-8A□03-FLK-UTU

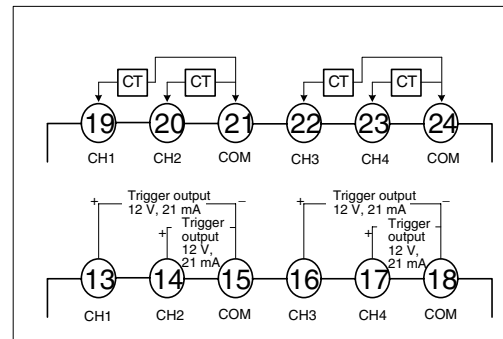

G3ZA-4H□03-FLK-UTU

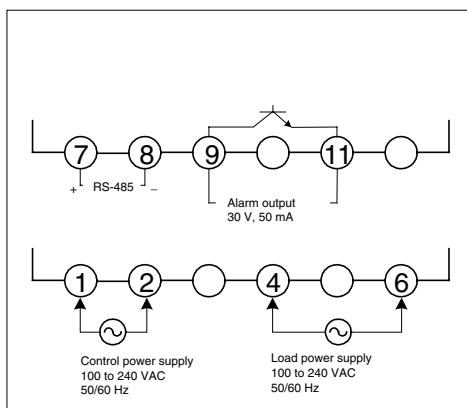
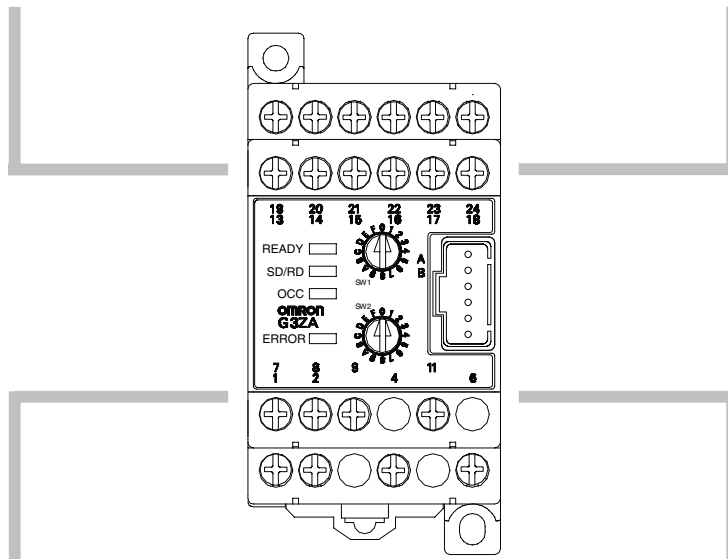

G3ZA-□□203-FLK-UTU

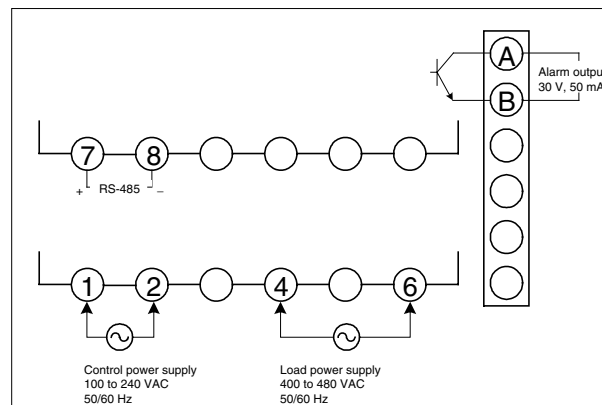

G3ZA-□□403-FLK-UTU

### Wiring Diagrams

Use one of the following M3 solderless terminals for wiring.

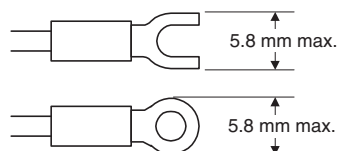

Use wires that are rated to withstand 70 °C minimum.

**Controller Power Supply Terminals**

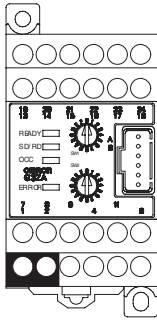

In the wiring diagrams, the area within the lines indicating terminals numbers is inside the G3ZA and the area outside the lines are outside the G3ZA.

- Connect terminals 1 and 2 as follows:

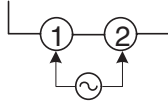

- The input power is 100 to 240 VAC.

**Load Power Supply Input Terminals**

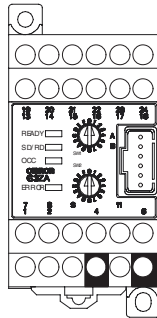

- To detect the zero-cross point of the load supply, connect the load power supply to terminals 4 and 6 as follows:

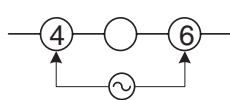

The voltage of the load power supply that can be connected depends on the model of the Controller.

100 to 240 VAC or 400 to 480 VAC

- The G3ZA detects the zero cross point of the load power supply.

**Communications Terminals**

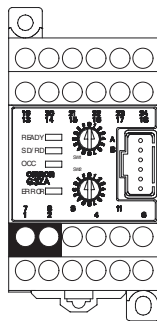

- To communicate with a host system, connect the communications line to terminals 7 and 8 as follows:

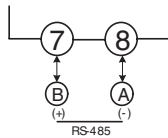

- The connection type can be 1: 1 or 1: N. For 1: N connections, up to 32 Units can be connected, including the host.
- The maximum cable length is 500 m total.

**Cable Diagram (Reference)**

- Use shielded twisted-pair cables (AWG28 to AWG16).

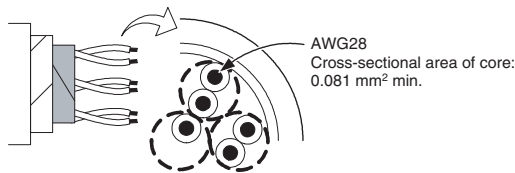

- A terminator must be connected to both ends of the communications path (including the PLC). Use a resistance of 100 to 125 Ω (1/2 W) in the terminators.
- Use an RS-232C/RS-485 converter to connect to a personal computer or other host with an RS-232C connection.

Converter: K3SC RS-232C/RS-485 Interface Converter

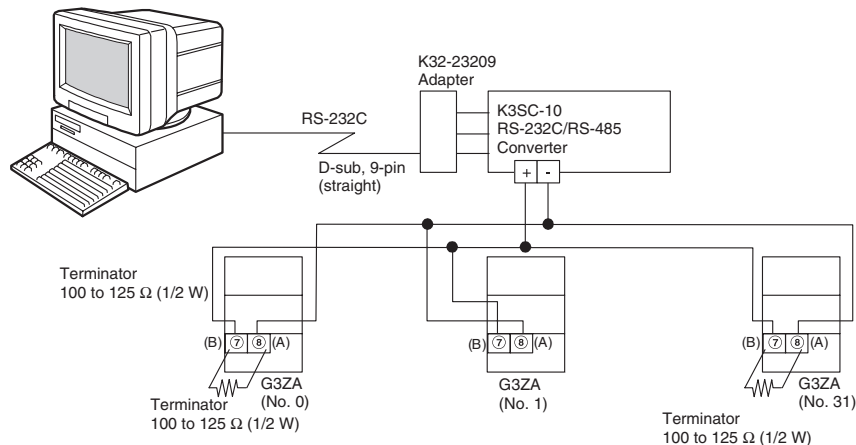

Alarm Output Terminals for the G3ZA-□□203-FLK-UTU

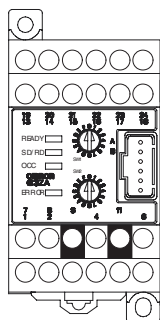

- Alarms are output on terminals 9 and 11.

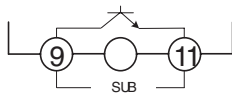

- The alarm output specifications are as follows:  
 Maximum load voltage: 30 VDC  
 Maximum load current: 50 mA  
 Maximum residual voltage: 1.5 V  
 Maximum leakage current: 1 mA

Alarm Output Terminals for the G3ZA-□□403-FLK-UTU

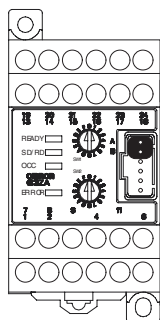

- Alarms are output on pins A and B of the connector.
- The alarm output specifications are as follows:

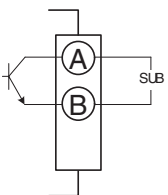

Maximum load voltage: 30 VDC  
 Maximum load current: 50 mA  
 Maximum residual voltage: 1.5 V  
 Maximum leakage current: 1 mA

- The C-Grid SL connector for Molex Incorporated can be used for the connector.

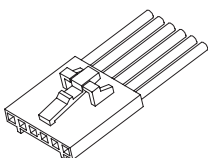

Model number: 51030-6030  
 C-Grid SL Housing  
 Model number: 52109-0660  
 C-Grid SL Housing/Press-fit Type

- The G3ZA-A300C Cable from OMRON also can be used.

Preparations

**Trigger Output Terminals**

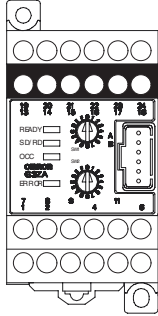

- The trigger outputs for channels 1 to 4 are output on terminals 13 to 18.

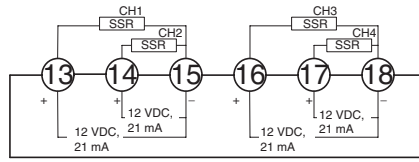

Output voltage: 12 VDC  $\pm$ 15%  
 PNP  
 Maximum load current: 21 mA  
 Short-circuit protection circuit provided.

**Controllers without a Current Transformer Input Circuit (G3ZA-8A□03-FLK-UTU)**

- The trigger outputs for channels 5 to 8 are output on terminals 19 to 24.

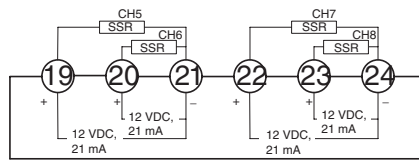

**Current Transformer Input Terminals**

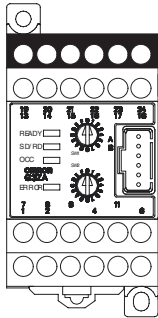

**Controllers with Built-in Current Transformer Circuits (G3ZA-4H□03-FLK-UTU)**

- Connect terminals 19 to 24 to the current transformers (no polarity) to detect heater burnouts, heater overcurrents, and SSR short circuits.

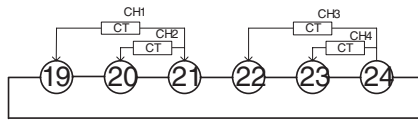

There are four current transformer inputs that can be used.  
 Use the E54-CT1 or the E54-CT3 from OMRON as the current transformer.

**Wiring Example (G3ZA-4H□03-FLK-UTU)**

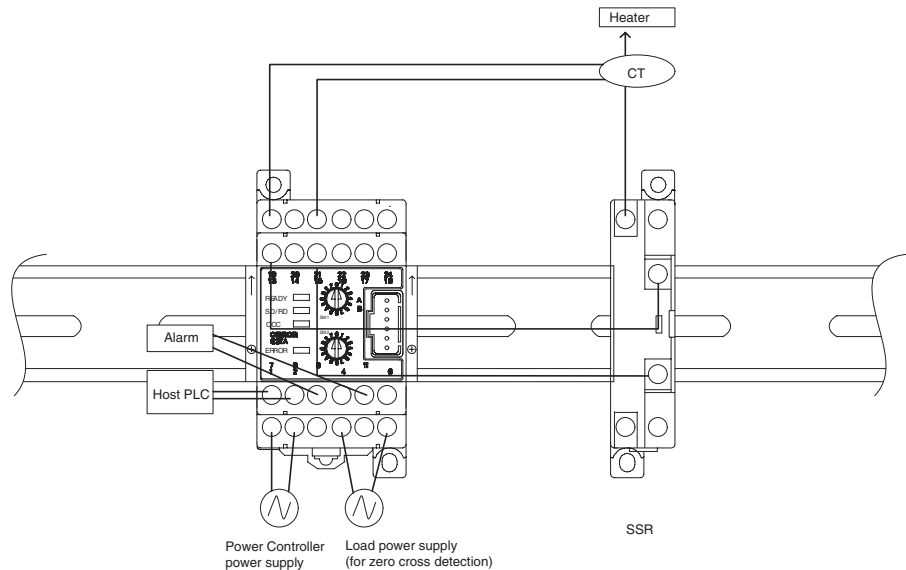

# SECTION 3

## Using the G3ZA

This section describes application information, including settings, communications, and controlling operation.

- 3-1 Communications Settings ..... 14
- 3-2 CompoWay/F Frame Structure ..... 15
- 3-3 FINS-mini Text ..... 17
- 3-4 Variable Area Write ..... 17
- 3-5 Variable Area Read ..... 18
- 3-6 Operation Command ..... 19
- 3-7 Controller Attribute Read ..... 20
- 3-8 Controller Status Read ..... 21
- 3-9 Echo-back Test ..... 22

Using the G3ZA

### 3-1 Communications Settings

G3ZA settings and operation are performed using RS-485 communications.

#### Communications Specifications

Transmission path connections	Multipoint
Communications method	RS-485
Sync method	Stop-start sync
Baud rate	9.6, 19.2, 38.4 or 57.6 kbit/s
Transmission code	ASCII
Data length	7 or 8 bits
Stop bits	1 or 2 bits
Error detection	Vertical priority: None, even, or odd
Flow control	None

Communications settings are made as shown in the following table.

Setting	Setting range	Default	Setting method
Communications unit number	0 to 31	1	SW1
Baud rate	9.6, 19.2, 38.4 or 57.6 kbit/s	9.6 kbit/s	SW2
Data length	7 or 8 bits	7 bits	Communications
Stop bits	1 or 2 bits	2 bits	Communications
Parity	None, even, odd	Even	Communications
Send standby time	0 to 99 ms	20 ms	Communications

#### Setting the Communications Unit Number and Baud Rate

The communications unit number and baud rate are set first. These settings are made with SW1 and SW2 on the front of the G3ZA.

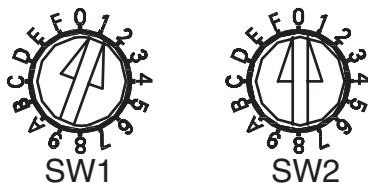

SW1	0	1	2	3	4	5	6	7	8	9	A	B	C	D	E	F
Unit number	00	01	02	03	04	05	06	07	08	09	10	11	12	13	14	15

SW2	0	1	2	3
Baud rate (kbit/s)	9.6	19.2	38.4	57.6

- Note**
- (1) Refer to *Connecting More Than 16 Controllers* on page 38 in the *Appendix* when connecting more than 16 Controllers.
  - (2) The default settings are shaded in the above table.

#### Other Communications Settings

Communications are used to set the data length, number of stop bits, parity, and send standby time. To change the settings, use communications with the default communications settings. Refer to *3-4 Variable Area Write* on page 17 for the procedure for changing these settings.

- Note** The settings will be enabled only when the power is turned ON again or the G3ZA is reset.

**Send Standby Time**

The send standby time is used to adjust the time required for the host to switch from sending to receiving status. For the G3ZA, this adjusts the time between creating a response after receiving a transmission and switching to send status.

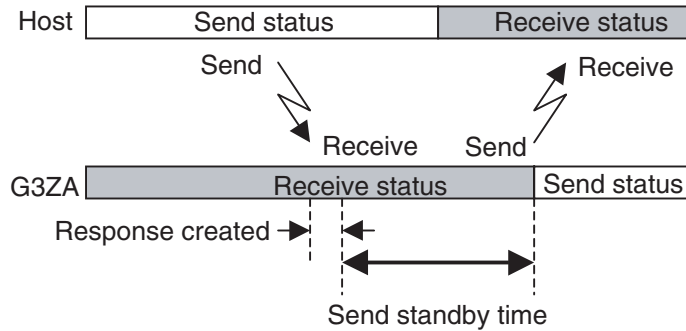

If switching time will not cause problems, the send standby time can be shortened to reduce the communications time with the host.

**3-2 CompoWay/F Frame Structure**

The propriety OMRON communications protocol called CompoWay/F is used as the communications protocol. Commands from the host and responses from the G3ZA are sent in data packets called frames. The structures of the command and response frames are shown below.

**Command Frames**

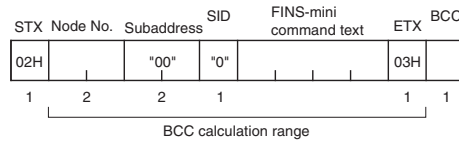

**Response Frames**

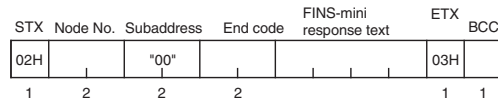

STX	Code that indicates the beginning of the communications frame. Always set 02H.
Node No.	This number specifies the destination. This is the same as the communications unit number set on SW1 and SW2.
Subaddress and SID	These are not used by the G3ZA. Set them to all zeros.
FINS-mini command text	The text of the command. Refer to 3-6 Operation Command on page 19 for details.
ETX	Code that indicates the end of the communications frame. Always set 03H.
BCC	This stores the result of the BCC calculation from the Node No. to EXT.

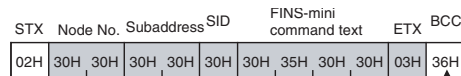

BCC = 30H⊕30H⊕30H⊕30H⊕30H⊕30H⊕35H⊕30H⊕30H⊕03H = 36H  
 ⊕ indicates an exclusive OR.

Using the G3ZA

**End Codes (CompoWay/F Communications)**

End code	Name	Description
"0F"	FINS command error	Could not execute the specified FINS command.
"10"	Parity error	Sum of bits that are "1" in received data does not agree with the set communications parity value.
"11"	Framing error	Stop bit is "0".
"12"	Overrun error	The next data was received when the received data buffer was full.
"13"	BCC error	Calculated BCC differs from received BCC.
"14"	Format error	Characters other than "0" to "9" or "A" to "F" in FINS-mini command text. (Refer to 3-9 <i>Echo-back Test</i> on page 22 for echo-back tests.)
"16"	Subaddress error	One or more of the subaddresses is missing.
"18"	Frame length error	The received frame exceeds the required number of bytes.
"00"	Normal end	Command was executed normally without error.

**Data Type Notation**

In this manual, hexadecimal and ASCII characters are expressed as shown in the following table.

Hexadecimal	An H is added to the end of the hexadecimal number. Example: 02H
ASCII characters	ASCII characters are given in quotation marks. Example: "00"

### 3-3 FINS-mini Text

The structure of FINS<sup>1</sup> command and response text is shown below.

#### Command Text

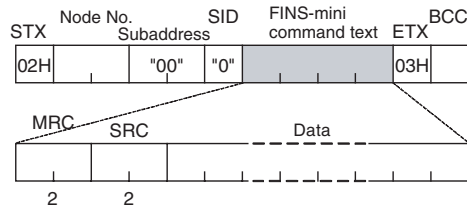

#### Response Text

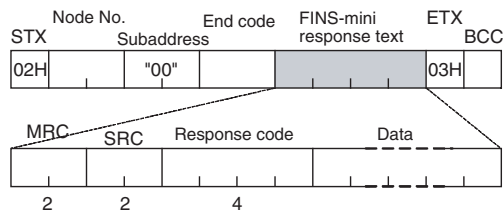

#### List of FINS-mini Service Commands

MRC	SRC	Service name	Description
"01"	"02"	Variable Area Write	Changes set values.
"01"	"01"	Variable Area Read	Reads set values.
"30"	"05"	Operation Command	Executes commands such as start/stop, manipulated variable save and software reset.
"05"	"03"	Controller Attribute Read	Reads the model number of the Controller.
"06"	"01"	Controller Status Read	Reads the operating status.
"08"	"01"	Echo-back Test	Performs an echo-back test.

Using the G3ZA

### 3-4 Variable Area Write

This command changes set values.

#### Command

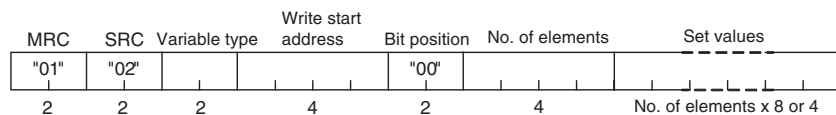

**Note** The bit position is not used. Set it to "00".

#### Response

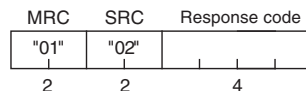

#### ■ Variable Type and Write Start Address

Refer to the *Parameter Tables* on page 38 in the *Appendix*.

1.FINS: Short for Factory Interface Network Service.  
The FINS protocol is used for message communications between controllers on OMRON FA networks.

■ **Number of Elements**

Specify the number of elements for which the set value is to be changed. Up to 8 elements can be specified.

■ **Response Code**

Response code	Error name	Cause
"1002"	Command length too short	The command is too short.
"1101"	Area type error	The specified variable type does not exist.
"1003"	Number of elements/Number of data do not agree	The specified number of elements does not agree with the actual number of data elements.
"1100"	Parameter error	The bit position specification is not "00". A set value is outside of the setting range.
"2203"	Operation error	An error occurred in nonvolatile memory.
"0000"	Normal end	Processing was completed normally.

**Example:** The following command changes the manipulated variable for channel 1 to 50% (set value: 8 digits).

Command: [STX]010000**102C10000000001000001F4**[ETX][BCC]

Response: [STX]010000**1020000**[ETX][BCC]

**Example:** The following command changes the manipulated variable for channel 1 to 50% (set value: 4 digits).

Command: [STX]010000**10281000000000101F4**[ETX][BCC]

Response: [STX]010000**1020000**[ETX][BCC]

### 3-5 Variable Area Read

This command reads set values.

**Command**

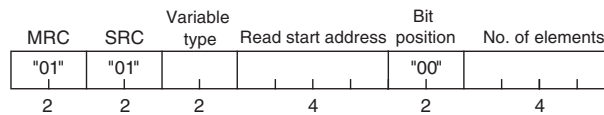

**Note** The bit position is not used. Set it to "00".

**Response**

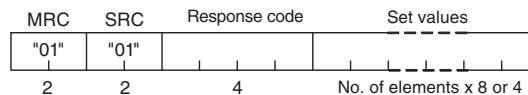

■ **Variable Type and Read Start Address**

Refer to the *Parameter Tables* on page 38 in the *Appendix*.

■ **Number of Elements**

Specify the number of elements for which the set value is to be read. Up to 8 elements can be specified.

■ Response Code

Response code	Error name	Cause
"1001"	Command length too long	The command is too long.
"1002"	Command length too short	The command is too short.
"1101"	Area type error	The specified variable type does not exist.
"110B"	Response length too long	The number of elements is larger than the maximum number allowed.
"1100"	Parameter error	The bit position specification is not "00".
"2203"	Operation error	An error occurred in nonvolatile memory.
"0000"	Normal end	Processing was completed normally.

**Example:** The following command reads the control variable for channel 1 (set value: 8 digits).

Command: [STX]010000101C00001000001[ETX][BCC]

Response: [STX]0100000101000000000000[ETX][BCC]

**Example:** The following command reads the control variable for channel 1 (set value: 4 digits).

Command: [STX]010000101800001000001[ETX][BCC]

Response: [STX]010000010100000000[ETX][BCC]

### 3-6 Operation Command

This command is used to start and stop operation, save the manipulated variable, execute a software reset, or initialize settings.

**Command**

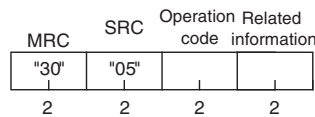

**Response**

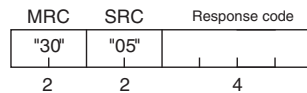

### 1. Operation Code and Related Information

Operation code	Description	Related information	Operation
"01"	Start/stop	Upper digit: Channel specification "0": Channel 1 "1": Channel 2 "2": Channel 3 "3": Channel 4 "4": Channel 5 "5": Channel 6 "6": Channel 7 "7": Channel 8 "F": All channels Lower digit: Start/stop "0": Start "1": Stop	Refer to 4-3 <i>Turning OFF the Control Output</i> on page 25.
"05"	Manipulated variable save	"00"	Refer to 4-1 <i>Changing the Manipulated Variable</i> on page 24.
"06"	Software reset	"00"	Performs the same processing as when the G3ZA is turned ON.
"0B"	Initialize settings	"00"	Refer to 5-2 <i>Handling Problems</i> .

**Note** There is no response for a software reset. Responses are returned for all other operation codes.

### 2. Response Codes

Response code	Error name	Cause
"1001"	Command length too long	The command is too long.
"1002"	Command length too short	The command is too short.
"1100"	Parameter error	The operation code or related information is not correct.
"2203"	Operation error	An error occurred in nonvolatile memory.
"0000"	Normal end	Processing was completed normally.

**Example:** The following command starts operation for channel 1.

Command: [STX]01000**30050100**[ETX][BCC]

Response: [STX]01000**30050000**[ETX][BCC]

## 3-7 Controller Attribute Read

This command reads the model number of the Controller and the communications buffer size.

### Command

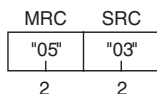

### Response

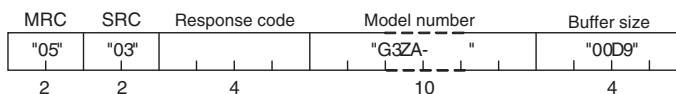

1. Model Number



Number	Code	Meaning
①	"4"	4 channels
	"8"	8 channels
②	"H"	With current transformer input
	"A"	No current transformer input
③	"2"	Load power supply: 100 to 240 V
	"4"	Load power supply: 400 to 480 V
④⑤	"03"	RS-485

2. Buffer Size

The buffer size is 217 bytes (D9H).

3. Response Code

Response code	Error name	Cause
"1001"	Command length too long	The command is too long.
"2203"	Operation error	An error occurred in nonvolatile memory.
"0000"	Normal end	Processing was completed normally.

**Example:** The following command reads the model number and buffer size. The response shows the Controller has four channels, supports a current transformer, and has a load power supply of 400 to 480 V.

Command: [STX]010000**503**[ETX][BCC]

Response: [STX]010000**5030000G3ZA-4H40300D9**[ETX][BCC]

### 3-8 Controller Status Read

This command reads the operating status of the Controller.

**Command**

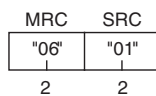

**Response**

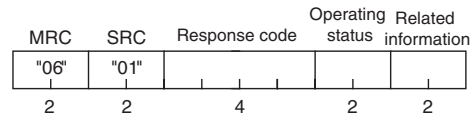

1. Operating Status

Operating status	Meaning
"00"	The control output is ON for one or more channels.
"01"	The Controller is stopped or a zero cross error has occurred during operation.

2. Related Information

An OR of status bits 0 to 7 for all channels.

Refer to the *Status* in the *Parameter Tables* in the *Appendix*.

**Note** To read the status of individual channels, use the Variable Area Read command for the desired channel. Refer to 3-5 *Variable Area Read* for details.

3. Response Code

Response code	Error name	Cause
"1001"	Command length too long	The command is too long.
"2203"	Operation error	An error occurred in nonvolatile memory.
"0000"	Normal end	Processing was completed normally.

**Example:**

Command: [STX]010000**601**[ETX][BCC]

Response: [STX]010000**60100000100**[ETX][BCC]

### 3-9 Echo-back Test

This command performs an echo-back test.

**Command**

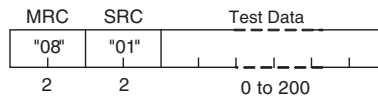

**Response**

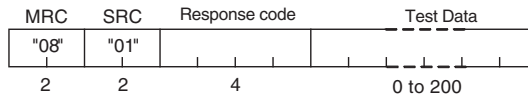

**1. Test Data**

Set the test data within the following ranges according to the communications data length setting.

Data length	Text data
7 bits	ASCII 20H to 7EH
8 bits	ASCII 20H to 7EH or A1H to FEH

**2. Response Codes**

Response code	Error name	Cause
"1001"	Command length too long	The command is too long.
"2203"	Operation error	An error occurred in nonvolatile memory.
"0000"	Normal end	Processing was completed normally.

**Example:**

Command: [STX]010000**801123**[ETX][BCC]

Response: [STX]010000**8010000123**[ETX][BCC]

# SECTION 4

## Functions

This section describes the functions of the G3ZA so that these functions can be used effectively according to the application.

4-1	Changing the Manipulated Variable . . . . .	24
4-2	Offsetting Control Output ON Timing . . . . .	25
4-3	Turning OFF the Control Output . . . . .	25
4-4	Detecting Heater Burnout (4-channel Models Only) . . . . .	26
4-5	Detecting Heater Overcurrent (4-channel Models Only) . . . . .	28
4-6	Detecting SSR Short Circuits (4-channel Models Only) . . . . .	28
4-7	Setting Operation for Errors . . . . .	30
4-8	Detecting Communications Timeouts . . . . .	30

## 4-1 Changing the Manipulated Variable

The Variable Area Write command is used to change the manipulated variable. The manipulated variable is 0.0% by default when the power supplied is turned ON. This value can be changed to another value by using the Manipulated Variable Save operation command.

**Example:** The following procedure can be used to change the manipulated variable to 20.0% whenever the power supply is turned ON.

- 1,2,3...**
1. Execute the Variable Area Write command to set the manipulated variable to 20.0% for all channels.
  2. Execute the Manipulated Variable Save operation command.
  3. The manipulated variables will be set to 20.0% the next time power is turned ON.

### Using Manipulated Variable Calculations

Manipulated variable calculations can be used to set the control variable for one change based on the manipulated variable for another channel. The following calculation method and set values can be used.

$$\text{Control variable} = \text{Manipulated variable of source channel} \times \text{Slope}/100.0 + \text{Offset}$$

Set value	Setting
Channels 1 to 8: Source channel	Channel 1 to 8 (Set the channel to use as the source for calculation.)
Channels 1 to 8: Slope	0.0% to 400.0%
Channels 1 to 8: Offset	-400.0% to 400.0%

- Note**
- (1) The control variable will be clamped at 0% or 100% if it exceeds the range of 0% to 100%.
  - (2) The control variable can be read using the Variable Area Read command.

**Example:**

Channel	1	2	3	4
Manipulated variable	0.0	20.0	0.0	0.0
Source channel	2	2	2	2
Slope	175.0	100.0	125.0	150.0
Offset	15.0	0.0	5.0	10.0
Control variable	50.0	20.0	30.0	40.0

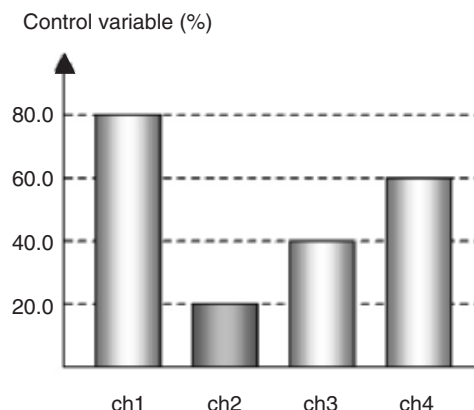

## 4-2 Offsetting Control Output ON Timing

The ON timing of control outputs for all of the channels can be adjusted to reduce overlapping with each other. Set the Offset Control to perform this. (Offset Control is enabled by default.)

### Disabled (No Offset)

In the following diagram, the ON timing overlaps between the channels.

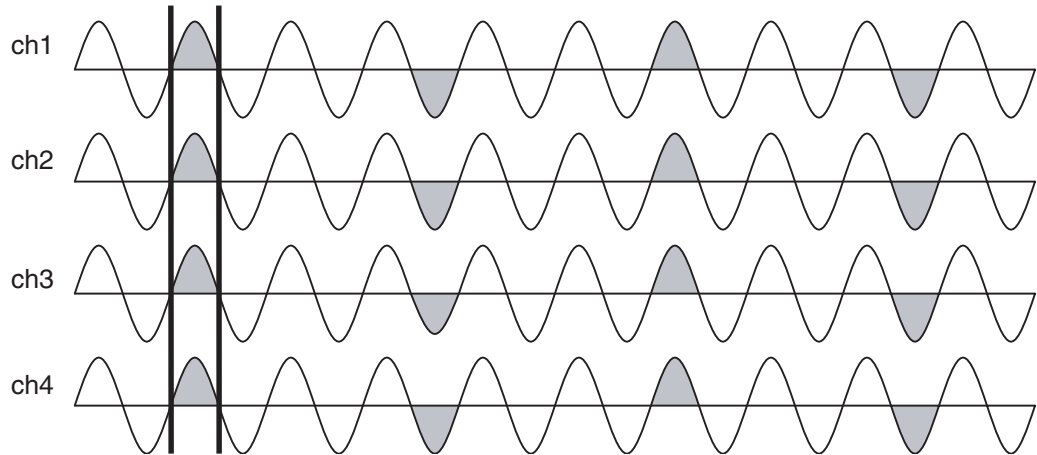

### Enabled (Offset)

In the following diagram, overlapping of the ON timing has been reduced.

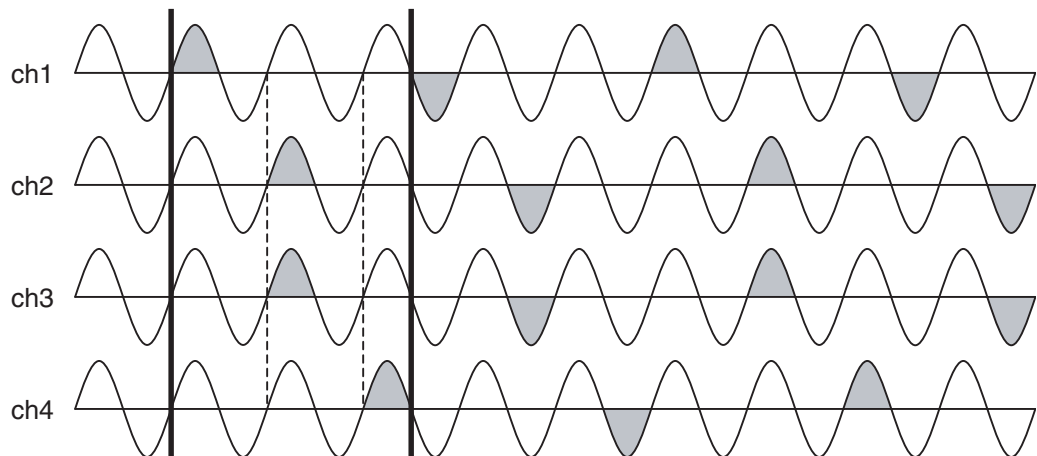

**Note** Overlapping will vary with the control variables and changes to the control variables.

## 4-3 Turning OFF the Control Output

Use the start/stop operation command to turn OFF control outputs. The start/stop command can be used for all channels or for individual channels.

**Note** The start/stop status is written to nonvolatile memory. If the power is turned OFF when a control output is stopped, it will still be stopped when power is turned back ON. Use the Start/Stop operation command to enable operation again.

## 4-4 Detecting Heater Burnout (4-channel Models Only)

A heater burnout is detected by determining if the heater current is below the heater burnout detection value when a control output is ON.

### Heater Burnout Detection Timing

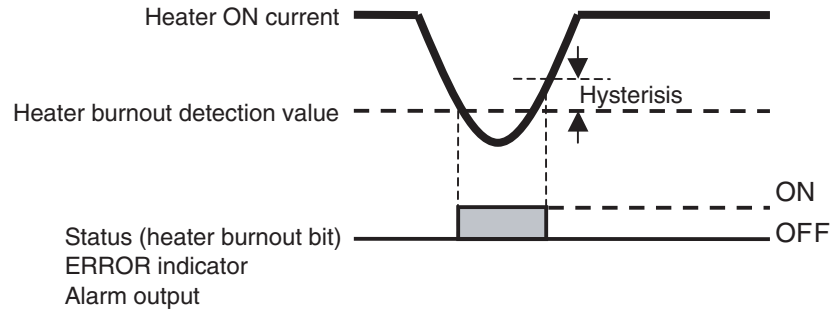

Set value	Setting range	Default
Channels 1 to 4: Heater burnout detection value	0 to 50 (See note 1.)	0 (disabled)
Hysteresis (See note 2.)	1 to 10	1

- Note**
- (1) Heater burnouts will not be detected if the detection value is set to 0. Detection status will be forced ON if the detection value is set to 50. Use these to check operation during installation.
  - (2) Hysteresis is used to prevent chattering at the detection point. The same hysteresis setting is used for all heater burnout detection, heater overcurrent detection, and SSR short-circuit detection functions.

### Operating Conditions

- Turn ON the power supply to the heater either simultaneously with or before the power supply to the G3ZA. False detection will occur if the heater power supply is turned ON after the G3ZA power supply.
- The actual current flowing in the heater may not be the same as the heater's rated current. Check the heater current under actually conditions using the Heater ON Current parameters for channels 1 to 4.
- Keep the total normal heater current to 50 A or less. If 55 A is exceeded, the Heater ON Current parameters for channels 1 to 4 will be 55.
- Detection will be unstable if there is only a small difference between the normal current and burnout current. To achieve stable detection, set the parameters so that there will be a difference of at least 2 A for heaters of less than 10 A and a difference of 3 A or more for heaters of 10 A or more.
  - Heaters of less than 10 A: Normal current - burnout current  $\geq 2$  A
  - Detection will not be stable if the difference is less than 2 A.
  - Heaters of 10 A or more: Normal current - burnout current  $\geq 3$  A
  - Detection will not be stable if the difference is less than 3 A.

If the conditions for stable detection cannot be met, increase the number of turns of the heater wire through the current transformer. The monitor value for the heater ON current is proportional to the number of turns.

Example:

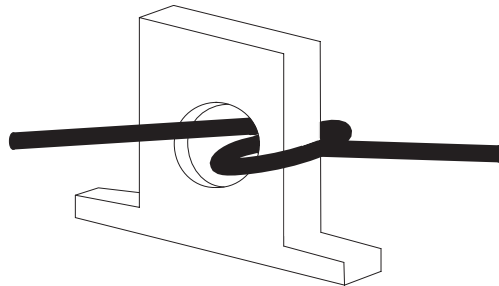

- Heater burnout detection status can be confirmed by reading the status for individual channels.

### Calculating the Detection Current for Heater Burnout

Use the following formula to calculate the detection current.

$$\text{Set value} = \frac{\text{Normal current} + \text{Burnout current}}{2}$$

When two or more heaters are connected through the current transformer, set the detection current to detect burnouts on the heater with the smallest current. If the heater currents are all the same, set the detection current for one wire.

#### Application Example

**Example 1:** Using one 1-kW heater (200 VAC)

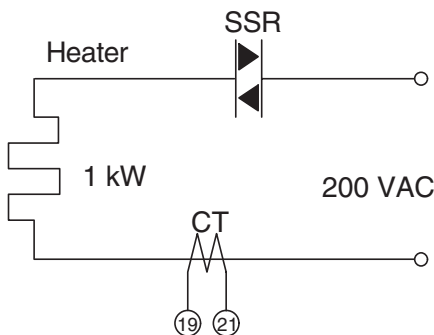

$$\text{Normal current} = \frac{1000}{200} = 5 \text{ A} (< 10 \text{ A})$$

$$\text{Burnout current} = 0 \text{ A}$$

$$\text{Set value} = \frac{5+0}{2} = 2.5 \text{ A} \cong 2 \text{ A}$$

$$(\text{Normal current} - \text{Burnout current} = 5 - 0 = 5 \text{ A} (\geq 2 \text{ A}))$$

The above calculation produces 2.5 A. The minimum setting unit is 1 A, so 2.5 is truncated and 2 A is used.

**Example 2:** Using three 1-kW heaters (200 VAC)

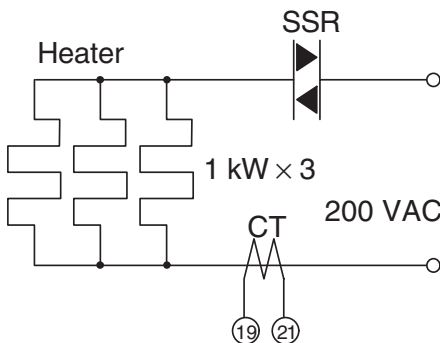

$$\text{Normal current} = \frac{1000}{200} \times 3 = 15 \text{ A} (\geq 10 \text{ A})$$

$$\text{Current for 1 heater} = \frac{1000}{200} \times 2 = 10 \text{ A}$$

$$\text{Set value} = \frac{15+10}{2} = 12.5 \text{ A} \cong 12 \text{ A}$$

$$(\text{Normal current} - \text{Burnout current} = 15 - 10 = 5 \text{ A} \geq 3 \text{ A})$$

The calculation produces 12.5 A. This is truncated to 12 A, as explained above.

## 4-5 Detecting Heater Overcurrent (4-channel Models Only)

A heater overcurrent is detected by determining if the heater current is above the heater overcurrent detection value when a control output is ON.

### Heater Overcurrent Detection Timing

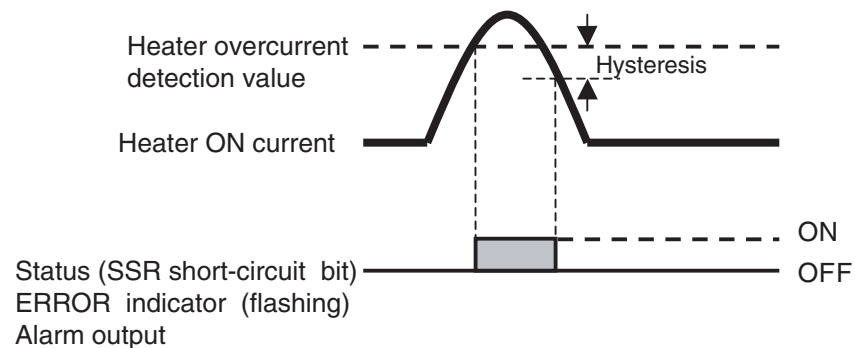

Set value	Setting range	Default
Channels 1 to 4: Heater overcurrent detection value	0 to 50 (See note 1.)	50 (disabled)
Hysteresis (See note 2.)	1 to 10	1

- Note**
- (1) Heater overcurrents will not be detected if the detection value is set to 50. Detection status will be forced ON if the detection value is set to 0. Use these to check operation during installation.
  - (2) Hysteresis is used to prevent chattering at the detection point. The same hysteresis setting is used for all heater burnout detection, heater overcurrent detection, and SSR short-circuit detection functions.

### Operating Conditions

- The actual current flowing in the heater may not be the same as the heater's rated current. Check the heater current under actually conditions using the Heater ON Current parameter for the relevant channel.
- Detection will be unstable if there is only a small difference between the normal current and overcurrent current. To achieve stable detection, set the parameters so that there will be a difference of at least 2 A for heaters of less than 10 A and a difference of 3 A or more for heaters of 10 A or more.
- Heater overcurrent detection status can be confirmed by reading the status for individual channels.

### Calculating the Detection Current for Heater Overcurrent

Set the detection current according to the needs of the application.

## 4-6 Detecting SSR Short Circuits (4-channel Models Only)

An SSR short-circuit is detected by determining if the heater current is above the SSR short-circuit detection value when a control output is OFF.

**SSR Short-circuit  
Detection Timing**

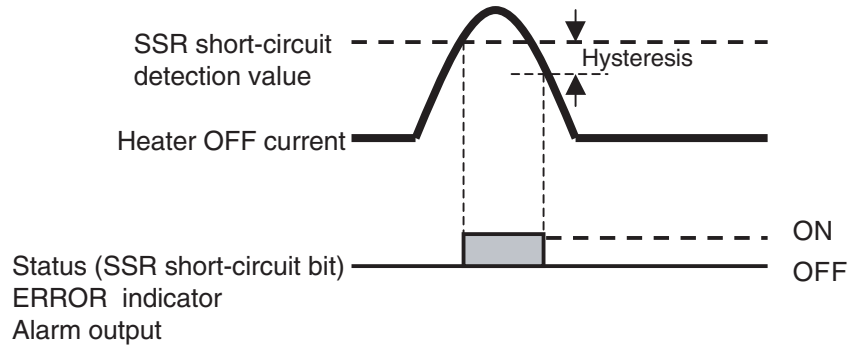

Set value	Setting range	Default
Channels 1 to 4: SSR short-circuit detection value	0 to 50 (See note 1.)	50 (disabled)
Hysteresis (See note 2.)	1 to 10	1

- Note**
- (1) SSR short-circuits will not be detected if the detection value is set to 50. Detection status will be forced ON if the detection value is set to 0. Use these to check operation during installation.
  - (2) Hysteresis is used to prevent chattering at the detection point. The same hysteresis setting is used for all heater burnout detection, heater overcurrent detection, and SSR short-circuit detection functions.

**Operating Conditions**

- The actual current flowing in the heater may not be the same as the heater's rated current. Check the heater current under actually conditions using the Heater OFF Current parameters for channels 1 to 4.
- SSR short-circuit detection status can be confirmed by reading the status for individual channels.

**Calculating the Detection Current for SSR Short-circuits**

Set the detection current to the value calculated with the following formula or higher.

**Set value > Normal leakage current x 2**

## 4-7 Setting Operation for Errors

The operation to be used when the following errors occur can be set.

- Zero cross error (See note 2.)
- Heater burnout detection
- Heater overcurrent detection
- SSR short-circuit detection

Operation at error	Operation	Clearing the error
Continue with error clear	Continues.	The error is cleared when normal status is recovered (i.e., the status ERROR indicator and alarm output are turned OFF).
Continue without error clear	Continues.	The error is not cleared even if normal status is recovered. Restore normal status and then use an Operation Command Start operation again.
Stop	Stops for the channel with an error. (See note.)	The error is not cleared even if normal status is recovered and operation will remained stopped. Restore normal status and then use an Operation Command Start operation.

- Note**
- (1) Operation will stop for all channels if a zero cross error occurs.
  - (2) Zero cross error: A zero cross error will occur when there is an error in the load power supply voltage, frequency, or waveform. Refer to *SECTION 5 Troubleshooting* for details.

## 4-8 Detecting Communications Timeouts

Operation can be stopped if the time when normal communications cannot be performed exceeds the communications timeout time.

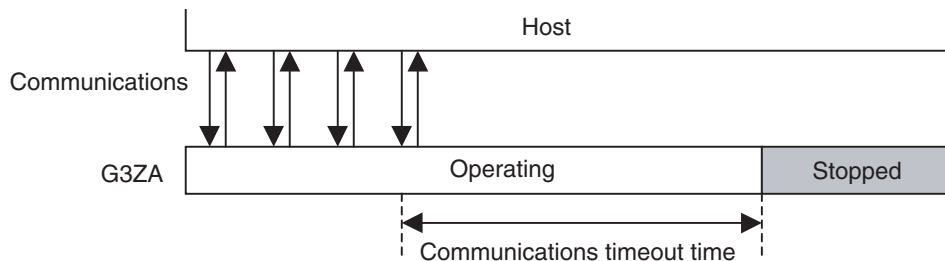

Set value	Setting range	Default
Communications timeout time	0 to 60 min	0 (disabled)

- Note**
- (1) Communications timeouts will not be detected if the time is set to 0.
  - (2) The setting is not valid and communications timeout detection will not start until the G3ZA is reset or until the power supply is cycled.

Operation will stop when a communications timeout is detected and the communications error bit in status, the ERROR indicator, and the alarm output will turn ON. Use an Operation Command to clear the error.

# SECTION 5

## Troubleshooting

This section provides information on problems that may occur during operation and corrective measures for them.

5-1	Errors.....	32
5-2	Handling Problems .....	33

## 5-1 Errors

### Error Table

ERROR indicator	Status	Operation	Error	Correction
Lit	No response or an error response	Stops	There is an error in internal memory or in non-volatile memory.	<p>Cycle the power supply.</p> <p>If operation does not recover, use the following procedure, noting that all settings will be returned to their default values.</p> <ul style="list-style-type: none"> <li>• Error Response Received Initialize the settings and perform a software reset with an Operation Command.</li> <li>• Error Response Not Received Set the host data length, stop bits, and parity to the default values for the G3ZA (if a Converter is being used, set it to the same values) and then initialize the settings and perform a software reset with an Operation Command.</li> </ul> <p>If operation still does not recover, the G3ZA needs to be repaired.</p>
Lit	Communications error bit is ON.	Stops	A communications timeout has occurred.	<ul style="list-style-type: none"> <li>• Check to see if the communications line is broken.</li> <li>• Check to see if a communications error has occurred.</li> <li>• Check the host to see if it is functioning correctly.</li> <li>• Check the information provided in <i>4-8 Detecting Communications Timeouts</i> on page 30.</li> </ul>
Lit	Zero cross error bit is ON.	According to the operation at error setting	A zero cross error has been detected.	<ul style="list-style-type: none"> <li>• Check to see if the load power supply's voltage and frequency are within specifications. The specified ranges are as follows: Controllers with 100 to 240 V Load Voltage: 75 to 264 VAC Controllers with 400 to 480 V Load Voltage: 340 to 528 VAC Frequency (all models) : 47 to 63 Hz</li> <li>• Noise may be a factor. Check the load power supply line for noise and check the general area around the G3ZA for noise.</li> </ul>
Lit	Heater burnout bit is ON.	According to the operation at error setting	A heater burnout has been detected.	<ul style="list-style-type: none"> <li>• The heater has burned out. Repair the heater or the heater line.</li> <li>• Check the information provided in <i>4-4 Detecting Heater Burnout (4-channel Models Only)</i> on page 26.</li> </ul>
Lit	Heater overcurrent bit is ON.	According to the operation at error setting	A heater overcurrent has been detected.	<ul style="list-style-type: none"> <li>• An overcurrent has occurred to the heater. Return the current to the correct range.</li> <li>• Check the information provided in <i>Wiring Diagrams</i> on page 9 and in <i>4-5 Detecting Heater Overcurrent (4-channel Models Only)</i> on page 28.</li> </ul>
Flashing	SSR short-circuit bit is ON.	According to the operation at error setting	An SSR short-circuit has been detected.	<ul style="list-style-type: none"> <li>• The SSR has short-circuited. Replace the SSR.</li> <li>• Check the information provided in <i>Wiring Diagrams</i> on page 9 and in <i>4-6 Detecting SSR Short Circuits (4-channel Models Only)</i> on page 28.</li> </ul>

## 5-2 Handling Problems

### Handling Problems

#### Preliminary Checks

Check item	Items to check
Is the power supply turned ON?	If the power supply is turned ON, the READY indicator will be lit.
Was wiring performed correctly?	Check all of the wiring.
Were settings performed correctly?	<ul style="list-style-type: none"> <li>• Check the switches to see if they are set correctly.</li> <li>• Read out the settings to see if they have been set correctly.</li> <li>• Read out all settings to see if any of them are incorrect.</li> </ul>

#### Handling Problems

Condition	Correction
Communications cannot be performed.	<ul style="list-style-type: none"> <li>• If the SD/RD indicator does not light when communications are attempted, there is a problem with the communications line. Check the wiring of the communications line.</li> <li>• If a communications converter is being used, check the settings of the converter to see if they are correct.</li> <li>• Check the settings of SW1 and SW2 to see if they agree with the settings of the host.</li> <li>• Check the data length, number of stop bits, and parity to see if they are the same as the host. If any of the settings are incorrect or if any are unknown, use the following method for communications.                             <ol style="list-style-type: none"> <li>1. Set SW2 to 7. (If more than 16 communications unit numbers are used, set SW2 to F.)</li> <li>2. Set the baud rate, data length, number of stop bits, and parity of the host to the default values for the G3ZA. If a converter is being used, set the converter to the same values.</li> <li>3. This should enable communications. Change all settings to the correct values.</li> </ol> </li> <li>• Check the communications line to see if it is correct.</li> </ul>
Outputs do not turn ON.	<ul style="list-style-type: none"> <li>• Unless the OCC indicator is lit or the control variable is set to 0.0%, then there is a problem in the wiring. Check the wiring of the control outputs.</li> <li>• If the ERROR indicator is lit or flashing, refer to the corrections given in the <i>Error Table</i> on page 32.</li> </ul>
Returning settings to default values	<ul style="list-style-type: none"> <li>• Initialize the settings with an Operation Command. All of the settings can be returned to their default values. Refer to the <i>Parameter Tables</i> on page 38 in the <i>Appendix</i> for default values.</li> </ul>



# Appendix

## Specifications

### Specifications

#### Ratings

<b>Control power supply voltage</b>	100 to 240 VAC (50/60 Hz)
<b>Control power supply voltage range</b>	85 to 264 VAC
<b>Power consumption</b>	Approx. 5.9 W
<b>Load power supply voltage</b>	100 to 240 VAC 400 to 480 VAC
<b>Load power supply voltage range</b>	Controllers for 100 to 240 VAC: 75 to 264 VAC Controllers for 400 to 480 VAC: 340 to 528 VAC
<b>Manipulated variable inputs</b>	0.0% to 100.0% (via RS-485 communications)
<b>Current transformer inputs</b>	Single-phase AC, 0 to 50 A
<b>Trigger outputs</b>	One for each channel, 12 VDC $\pm$ 15%, max. load current: 21 mA (with built-in short-circuit protection circuit)
<b>Alarm output</b>	NPN open collector, one output (Max. load voltage: 30 VDC, max. load current: 50 mA, max. residual voltage: 1.5 V, max. leakage current: 1.0 mA)
<b>Indications</b>	LED indicators
<b>Ambient operating temperature</b>	-10 to 55°C (with no icing or condensation)
<b>Ambient operating humidity</b>	25% to 85%
<b>Storage temperature</b>	-25 to 65°C (with no icing or condensation)
<b>Elevation</b>	2,000 m max.
<b>Accessories</b>	Instruction Sheet

#### Performance

<b>Current accuracy</b>	$\pm$ 3 A
<b>Insulation resistance</b>	100 M $\Omega$ min. (at 500 VDC) between primary and secondary
<b>Dielectric strength</b>	2,000 VAC, 50/60 Hz for 1 min between primary and secondary
<b>Vibration resistance</b>	Vibration frequency: 10 to 55 to 10 Hz, acceleration: 50 m/s <sup>2</sup> in X, Y, Z directions
<b>Shock resistance</b>	300 m/s <sup>2</sup> three times each in six directions along three axes
<b>Weight of main body</b>	Approx. 200 g (including terminal cover)
<b>Degree of protection</b>	IP20
<b>Memory backup</b>	EEPROM (non-volatile memory), write life: 100,000 writes
<b>Installation environment</b>	Overvoltage category III, pollution degree 2 (according to IEC 60664-1)
<b>Approved standards</b>	UL508 (Listing), CSA22.2 No. 14 EN50178 EN61000-6-4 (EN55011: 1998, A1: 1999 Class A, Group 1) EN61000-6-2: 2001

## Model Numbers

### Model Numbers

#### G3ZA-①②③④⑤-⑥-⑦

Number	Code	Specifications
①	No. of control points	4 8
		4 channels 8 channels
②	Control method	None Ideal cycle control
③	Current transformer input	H A
		Yes None
④	Load power supply voltage	2 4
		100 to 240 VAC 400 to 480 VAC
⑤	Communications specifications	03 RS-485
⑥	Communications protocol	FLK CompoWay/F
⑦	International standards	UTU Approved by TÜV.

## Current Transformer

### Specifications

Item	Specification	
Model number	E54-CT1	E54-CT3
Max. continuous heater current	50 A	120 A (See note.)
Dielectric strength	1,000 VAC for 1 min	
Vibration resistance	98 m/s <sup>2</sup> , 50 Hz	
Weight	Approx. 11.5 g	Approx. 50 g
Accessories	None	Connection terminals (2) Plugs (2)

**Note** The maximum continuous current of the G3ZA is 50 A.

### Dimensions (Unit: mm)

#### E54-CT1

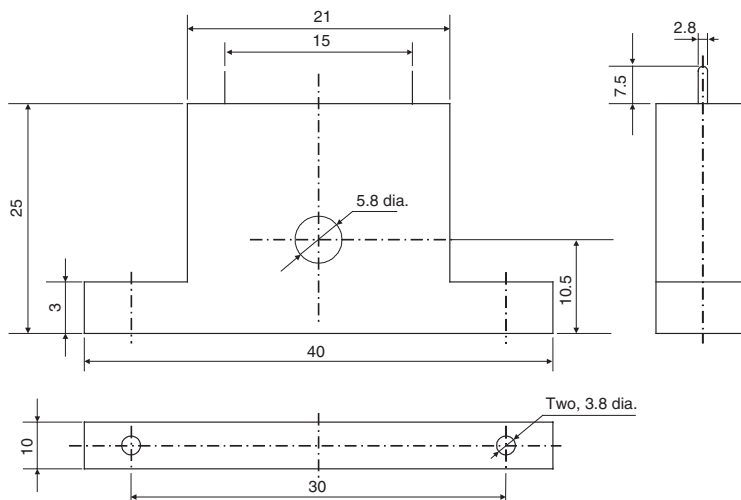

**E54-CT3**

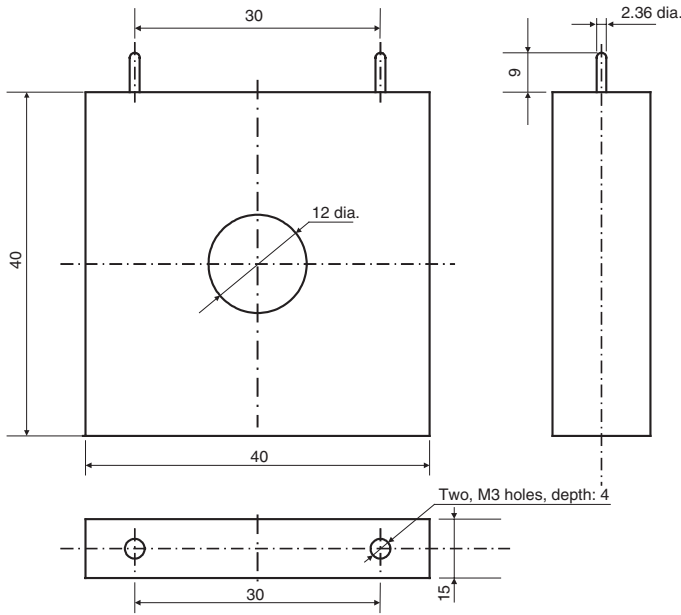

**Startup Operation**

It takes about 1 second for the load power supply to stabilize after the power supply to the G3ZA is turned ON. Outputs will not turn ON during this period. A stabilization period of 1 second is also executed after clearing a zero cross error.

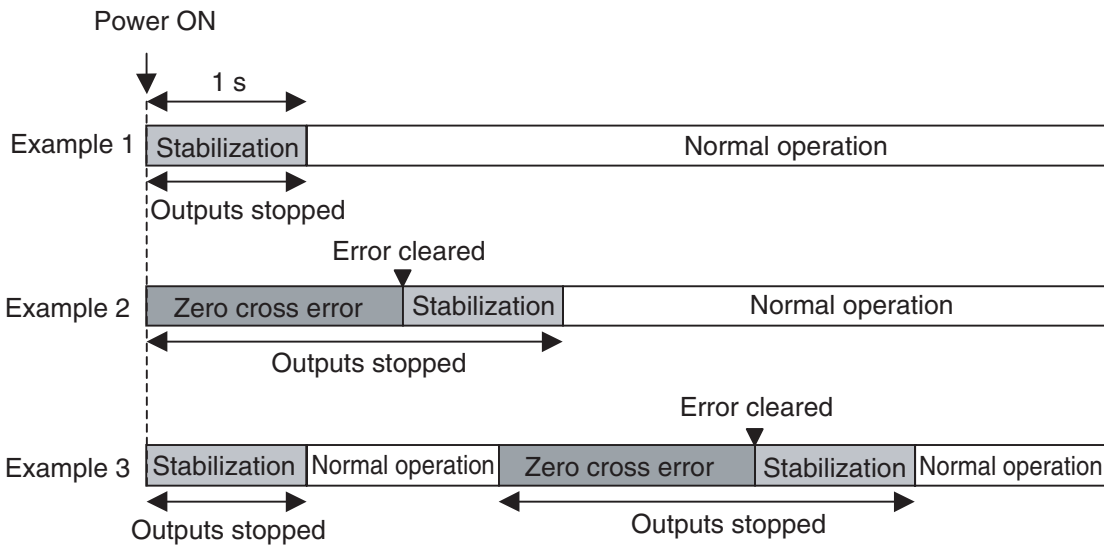

## Connecting More Than 16 Controllers

If more than 16 G3ZA Controllers are connected, set SW2 to between 8 and B for the 17th Controller on. The relationship between the settings of SW1 and SW2 is shown in the following table.

kbit/s	sw1 \ sw2	0	1	2	3	4	5	6	7	8	9	A	B	C	D	E	F
9.6	0	00	01	02	03	04	05	06	07	08	09	10	11	12	13	14	15
19.2	1																
38.4	2																
57.6	3																
---	4 to 7																
9.6	8	16	17	18	19	20	21	22	23	24	25	26	27	28	29	30	31
19.2	9																
38.4	A																
57.6	B																
---	C to F																

- Note**
- (1) Up to 31 Controllers can be connected.
  - (2) Do not set SW2 to between 4 and 7 or C and F.
  - (3) It's easiest to set the communications unit number first and then the baud rate.

**Setting example:** The following settings would be used to set a Controller to communications unit number 7 and a baud rate of 38.4 kbit/s.

SW1 = 7 and SW2 = 2

## Parameter Tables

### Parameter Tables

#### Status

Bit	Status	OFF	ON	
31 to 13	Not used.	OFF	---	
12	Start/stop	Operating	Stopped	Operating
11	Not used.	OFF	---	
10	Not used.	OFF	---	
9	Alarm output (applies to all channels)	OFF	ON	Output
8	Control output	OFF	ON	
7	Not used.	OFF	---	
6	Not used.	OFF	---	
5	Communications error (applies to all channels)	No	Yes	Error
4	Zero cross error (applies to all channels)	No	Yes	
3	Not used.	OFF	---	
2	Heater overcurrent	No	Yes	
1	SSR short circuit	No	Yes	
0	Heater burnout	No	Yes	

#### Example:

Condition	Status
Alarm output and zero cross error bit are ON.	H'00000210
Stopped with no errors	H'00001000

Level	Variable type	Address	Parameter	Setting/monitor range	Default	Unit	
Operation	C0 (See note 1.)	0000	Version	---	---	---	
		0001	CH1 control variable	H'00000000 to H'000003E8 (0.0 to 100.0)	0.0	%	
		0002	CH2 control variable	H'00000000 to H'000003E8 (0.0 to 100.0)	0.0	%	
		0003	CH3 control variable	H'00000000 to H'000003E8 (0.0 to 100.0)	0.0	%	
		0004	CH4 control variable	H'00000000 to H'000003E8 (0.0 to 100.0)	0.0	%	
		0005	CH5 control variable	H'00000000 to H'000003E8 (0.0 to 100.0)	0.0	%	
		0006	CH6 control variable	H'00000000 to H'000003E8 (0.0 to 100.0)	0.0	%	
		0007	CH7 control variable	H'00000000 to H'000003E8 (0.0 to 100.0)	0.0	%	
		0008	CH8 control variable	H'00000000 to H'000003E8 (0.0 to 100.0)	0.0	%	
		0009	CH1 status	---		---	
		000A	CH2 status	---		---	
		000B	CH3 status	---		---	
		000C	CH4 status	---		---	
		000D	CH5 status	---		---	
		000E	CH6 status	---		---	
		000F	CH7 status	---		---	
		0010	CH8 status	---		---	
		0011	CH1 heater ON current	H'00000000 to H'00000037 (0 to 55)	0	A	
	0012	CH2 heater ON current	H'00000000 to H'00000037 (0 to 55)	0	A		
	0013	CH3 heater ON current	H'00000000 to H'00000037 (0 to 55)	0	A		
	0014	CH4 heater ON current	H'00000000 to H'00000037 (0 to 55)	0	A		
	0015	CH1 heater OFF current	H'00000000 to H'00000037 (0 to 55)	0	A		
	0016	CH2 heater OFF current	H'00000000 to H'00000037 (0 to 55)	0	A		
	0017	CH3 heater OFF current	H'00000000 to H'00000037 (0 to 55)	0	A		
	0018	CH4 heater OFF current	H'00000000 to H'00000037 (0 to 55)	0	A		
		C1 (See note 1.)	0000	CH1 manipulated variable	H'00000000 to H'000003E8 (0.0 to 100.0)	0.0	%
			0001	CH2 manipulated variable	H'00000000 to H'000003E8 (0.0 to 100.0)	0.0	%
			0002	CH3 manipulated variable	H'00000000 to H'000003E8 (0.0 to 100.0)	0.0	%
			0003	CH4 manipulated variable	H'00000000 to H'000003E8 (0.0 to 100.0)	0.0	%
	0004		CH5 manipulated variable	H'00000000 to H'000003E8 (0.0 to 100.0)	0.0	%	
	0005		CH6 manipulated variable	H'00000000 to H'000003E8 (0.0 to 100.0)	0.0	%	
	0006		CH7 manipulated variable	H'00000000 to H'000003E8 (0.0 to 100.0)	0.0	%	
	0007		CH8 manipulated variable	H'00000000 to H'000003E8 (0.0 to 100.0)	0.0	%	
	0008		CH1 slope	H'00000000 to H'00000FA0 (0.0 to 400.0)	100.0	%	
	0009		CH2 slope	H'00000000 to H'00000FA0 (0.0 to 400.0)	100.0	%	

Level	Variable type	Address	Parameter	Setting/monitor range	Default	Unit
Operation	C1 (See note 1.)	000A	CH3 slope	H'00000000 to H'00000FA0 (0.0 to 400.0)	100.0	%
		000B	CH4 slope	H'00000000 to H'00000FA0 (0.0 to 400.0)	100.0	%
		000C	CH5 slope	H'00000000 to H'00000FA0 (0.0 to 400.0)	100.0	%
		000D	CH6 slope	H'00000000 to H'00000FA0 (0.0 to 400.0)	100.0	%
		000E	CH7 slope	H'00000000 to H'00000FA0 (0.0 to 400.0)	100.0	%
		000F	CH8 slope	H'00000000 to H'00000FA0 (0.0 to 400.0)	100.0	%
		0010	CH1 offset	H'FFFFFF060 to H'00000FA0 (-400.0 to 400.0)	0.0	%
		0011	CH2 offset	H'FFFFFF060 to H'00000FA0 (-400.0 to 400.0)	0.0	%
		0012	CH3 offset	H'FFFFFF060 to H'00000FA0 (-400.0 to 400.0)	0.0	%
		0013	CH4 offset	H'FFFFFF060 to H'00000FA0 (-400.0 to 400.0)	0.0	%
		0014	CH5 offset	H'FFFFFF060 to H'00000FA0 (-400.0 to 400.0)	0.0	%
		0015	CH6 offset	H'FFFFFF060 to H'00000FA0 (-400.0 to 400.0)	0.0	%
		0016	CH7 offset	H'FFFFFF060 to H'00000FA0 (-400.0 to 400.0)	0.0	%
		0017	CH8 offset	H'FFFFFF060 to H'00000FA0 (-400.0 to 400.0)	0.0	%
		0018	CH1 source channel	H'00000001 to H'00000008 (1 to 8)	1	---
		0019	CH2 source channel	H'00000001 to H'00000008 (1 to 8)	2	---
		001A	CH3 source channel	H'00000001 to H'00000008 (1 to 8)	3	---
		001B	CH4 source channel	H'00000001 to H'00000008 (1 to 8)	4	---
		001C	CH5 source channel	H'00000001 to H'00000008 (1 to 8)	5	---
		001D	CH6 source channel	H'00000001 to H'00000008 (1 to 8)	6	---
		001E	CH7 source channel	H'00000001 to H'00000008 (1 to 8)	7	---
		001F	CH8 source channel	H'00000001 to H'00000008 (1 to 8)	8	---
		0020	CH1 heater burnout detection value	H'00000000 to H'00000032 (0 to 50)	0	A
		0021	CH2 heater burnout detection value	H'00000000 to H'00000032 (0 to 50)	0	A
		0022	CH3 heater burnout detection value	H'00000000 to H'00000032 (0 to 50)	0	A
		0023	CH4 heater burnout detection value	H'00000000 to H'00000032 (0 to 50)	0	A
		0024	CH1 SSR short-circuit detection value	H'00000000 to H'00000032 (0 to 50)	50	A
		0025	CH2 SSR short-circuit detection value	H'00000000 to H'00000032 (0 to 50)	50	A
		0026	CH3 SSR short-circuit detection value	H'00000000 to H'00000032 (0 to 50)	50	A
		0027	CH4 SSR short-circuit detection value	H'00000000 to H'00000032 (0 to 50)	50	A
		0028	CH1 heater overcurrent detection value	H'00000000 to H'00000032 (0 to 50)	50	A
		0029	CH2 heater overcurrent detection value	H'00000000 to H'00000032 (0 to 50)	50	A
		002A	CH3 heater overcurrent detection value	H'00000000 to H'00000032 (0 to 50)	50	A
002B	CH4 heater overcurrent detection value	H'00000000 to H'00000032 (0 to 50)	50	A		
002C	Offset control	H'00000000 (Disabled) H'00000001 (Enabled)	Enabled	---		

Level	Variable type	Address	Parameter	Setting/monitor range	Default	Unit
Operation	C3 (See note 1.)	0000	Data length (See note 2.)	H'00000000 (7) H'00000001 (8)	7	bits
		0001	Stop bits (See note 2.)	H'00000000 (1) H'00000001 (2)	2	bits
		0002	Parity (See note 2.)	H'00000000 (None) H'00000001 (Even) H'00000002 (Odd)	Even	---
		0003	Send standby time (See note 2.)	H'00000000 to H'00000063 (0 to 99)	20	ms
		0004	Communications time-out time (See note 2.)	H'00000000 (Disabled) H'00000001 to H'0000003C (1 to 60)	0	min
		0005	Operation at error	H'00000000 (Continue with error clear) H'00000001 (Continue with no error clear) H'00000002 (Stop) (See note 3.)	0	---
		0006	Offset value	H'00000000 to H'000003E8 (0.0 to 100.0)	20.0	%
		0007	Hysteresis	H'00000001 to H'0000000A (1 to 10)	1	A

- Note**
- (1) If C in the variable type is changed to 8, 4-digit data can be set or monitored.
  - (2) These settings are valid until the G3ZA is reset or the power is turned ON again.
  - (3) Only the channel with the error will stop.

## ASCII Character Table

Upper byte Lower byte	0	1	2	3	4	5	6	7
0	NUL	DLE	SPACE	0	@	P		p
1	SOH	DC1	!	1	A	Q	a	q
2	STX	DC2	"	2	B	R	b	r
3	ETX	DC3	#	3	C	S	c	s
4	EOT	DC4	\$	4	D	T	d	t
5	ENQ	NAK	%	5	E	U	e	u
6	ACK	SYN	&	6	F	V	f	v
7	BEL	ETB	'	7	G	W	g	w
8	BS	CAN	(	8	H	X	h	x
9	HT	EM	)	9	I	Y	i	y
A	LF	SUB	*	:	J	Z	j	z
B	VT	ESC	+	;	K	[	k	{
C	FF	FS	,	<	L	\	l	
D	CR	GS	-	=	M	]	m	}
E	SO	RS	.	>	N	^	n	~
F	SI	US	/	?	O	_	o	DEL



# Index

## A-B

alarm output, 2  
  terminals on 200-V Controllers, 11  
  terminals on 400-V Controllers, 11  
baud rate, 14

## C

communications specifications, 14  
communications terminals, 10  
communications timeout time, 30  
communications timeouts, 30  
communications unit number, 14  
CompoWay/F, 15  
  end codes, 16  
control channels  
  maximum number, 2  
control outputs  
  turning OFF, 25  
control power supply  
  terminals, 10  
controller attributes  
  reading, 20  
controller status  
  reading, 21  
crimp terminals, 9  
current transformer, 36  
  input terminals, 12

## D

data length, 14  
detecting heater burnout, 26  
detecting heater overcurrent, 28  
detecting SSR short-circuits, 28

## E

E54-CT1, 36  
E54-CT3, 37  
echo-back test, 22  
error detection, 2  
ERROR indicator, 3  
errors  
  setting operation for errors, 30

table, 32

## F-H

FINS-mini  
  command and response text, 17  
heater burnout, 26  
  calculating the detection current, 27  
  detection, 30  
  detection value, 26  
heater overcurrent  
  calculating the detection current, 28  
  detection, 28, 30  
  detection value, 27, 28  
hysteresis, 26, 28, 29

## I-L

ideal cycle control, 2  
initializing settings, 19  
installation, 2, 6  
  mounting, 6  
  removing, 7  
  using screws, 8  
load power supply terminals, 10

## M

manipulated variable  
  calculations, 2  
  calculations using, 24  
  changing, 24  
  saving, 19  
model numbers, 36

## O

OCC indicator, 3  
offset control, 2, 25  
offset for manipulated variable calculations, 24  
offsetting ON timing, 25  
  disabled, 25  
  enabled, 25  
operation command, 19

## **R**

READY indicator, 3

resetting

software reset, 19

## **S**

SD/RD indicator, 3

send standby time, 14, 15

set values

reading, 18

writing, 17

slope for manipulated variable calculations, 24

source channel for manipulated variable calculations, 24

specifications, 35

SSR short-circuit

calculating the detection current, 29

detection, 30

detection value, 29

SSRs, 2

starting operation, 19

startup operation, 37

stop bits, 14

stopping operation, 19

switches

SW1, 3

SW2, 3

## **T-Z**

trigger output terminals, 12

troubleshooting, 31

handling problems, 33

wiring example, 12

zero cross errors, 30

## Revision History

A manual revision code appears as a suffix to the catalog number on the front cover of the manual.

Cat. No. Z200-E1-01



The following table outlines the changes made to the manual during each revision. Page numbers refer to the previous version.

Revision code	Date	Revised content
01	April 2004	Original production

---

*Revision History*

---